

# RECLAMATION

*Managing Water in the West*

**Design Standards No. 13**

## **Embankment Dams**

**Chapter 9: Static Deformation Analysis  
Phase 4 (Final)**



## **Mission Statements**

The U.S. Department of the Interior protects America's natural resources and heritage, honors our cultures and tribal communities, and supplies the energy to power our future.

The mission of the Bureau of Reclamation is to manage, develop, and protect water and related resources in an environmentally and economically sound manner in the interest of the American public.

**Chapter Signature Sheet  
Bureau of Reclamation  
Technical Service Center**

**Design Standards No. 13**

# **Embankment Dams**

## **Chapter 9: Static Deformation Analysis**

**DS-13(9)-17:<sup>1</sup> Rhase 6 (Hlpcn)  
November 2011**

Chapter 9 - Static Deformation Analysis is an existing chapter within Design Standards No. 13 and was revised to include:

- Examples of actual settlement analyses related to embankment dams
- Minor corrections and editorial changes

---

<sup>1</sup> DS-13(9)-17 refers to Design Standards No. 13, chapter 9, revision 17.

**Prepared by:**

Ashok Chugh  
Ashok Chugh, P.E.  
Civil Engineer, Geotechnical Engineering Group 1

June 15, 2011  
Date

**Peer Review:**

William Engemoen  
William Engemoen, P.E.  
Geotechnical Engineer, Geotechnical Services Division

6/15/2011  
Date

**Security Review:**

Larry K. Nuss  
Larry K. Nuss, P.E.  
Structural Engineer, Structural Analysis Group

6/28/2011  
Date

**Recommended for Technical Approval:**

Thomas N. McDaniel  
Thomas McDaniel, P.E.  
Geotechnical Engineer, Geotechnical Engineering Group 2

6/15/2011  
Date

**Submitted:**

Karen Knight  
Karen Knight, P.E.  
Chief, Geotechnical Services Division

10/12/2012  
Date

**Approved:**

Lowell Pimley  
Lowell Pimley, P.E.  
Director, Technical Service Center

11/6/12  
Date

# Contents

	<i>Page</i>
Chapter 9: Static Deformation Analysis	
9.1 Introduction.....	9-1
9.1.1 Purpose.....	9-1
9.1.2 Scope.....	9-1
9.1.3 Deviations from Standard .....	9-1
9.1.4 Revisions of Standard .....	9-2
9.1.5 Applicability .....	9-2
9.2 Embankment Deformations .....	9-2
9.2.1 Causes of Deformations.....	9-2
9.2.2 Factors Controlling Deformations .....	9-2
9.2.3 Effects of Deformations.....	9-4
9.2.4 Patterns of Deformations .....	9-4
9.3 Estimating Embankment Deformations.....	9-7
9.3.1 Need .....	9-7
9.3.2 Procedures.....	9-8
9.4 Defensive Design Measures.....	9-10
9.4.1 Limiting Deformations.....	9-10
9.4.2 Accepting Deformations .....	9-11
9.5 Performance Monitoring.....	9-12
9.5.1 Purpose.....	9-12
9.5.2 Instruments.....	9-12
9.6 Existing Dams.....	9-15
9.7 Additional Information .....	9-15
9.8 References.....	9-15
9.8.1 Supplemental References.....	9-16

## Figures

<i>Figure</i>	<i>Page</i>
9.2.4-1 Generalized pattern of horizontal surface deformations of an embankment dam. ....	9-5
9.2.4-2 Generalized pattern of movements along maximum section of an embankment dam. ....	9-6
9.2.4-3 Generalized pattern of movements along centerline of an embankment dam. ....	9-7

## Photos

<i>Photo</i>	<i>Page</i>
9.5.2-1. Typical instrumentation to monitor embankment and foundation deformations. ....	9-13

## Appendices

### *Appendix*

- A Example Problem
- B Examples of Settlement Analyses Related to Real Dams

## Chapter 9

# Static Deformation Analysis

## 9.1 Introduction

### 9.1.1 Purpose

This chapter is intended to provide a guideline for designers to use when estimating vertical deformations of an embankment dam during normal operations (static conditions). Earthquake-induced deformations are discussed in Chapter 13 – Seismic Design and Analysis—of this design standard. Static deformation estimates are used in designing crest camber, evaluating the possibility of the impervious core cracking, and estimating settlements of structures partially founded on, totally founded on, or buried within the embankment.

### 9.1.2 Scope

The scope of this chapter is limited to (1) providing the reader with a basic understanding of the factors that control embankment deformations under static loading, (2) presenting typical patterns of embankment deformations, (3) illustrating simplified methods for estimating crest settlements of compacted embankments on competent foundations, (4) providing guidelines for determining when a more complex analytical or physical modeling procedure should be performed, and (5) providing examples of actual settlement analyses related to embankment dams.

For the purposes of this discussion, a competent foundation is any foundation in which the foundation deformations are of negligible magnitude when compared to the embankment deformations. The magnitude of foundation deformation is related to type of rock, rock jointing, joint filling, density of overburden soil, height of the dam, and other factors. Special cases of foundation materials specifically not covered by this standard include karstic rock, permafrost, and highly compressible, liquefiable, collapsible, sensitive, and swelling soils. If these materials are encountered, the designer will need to research the problem and methodology for handling them.

### 9.1.3 Deviations from Standard

Deformation analyses performed within the Bureau of Reclamation (Reclamation) should conform to this standard. Deviations from this standard should be

documented and approved. The rationale for not using the standard should be described in the documentation. The technical documentation must be approved by appropriate line supervisors and managers.

### **9.1.4 Revisions of Standard**

This chapter will be revised as its use indicates. Comments or suggested revisions should be forwarded to the Chief, Geotechnical Services Division (86-68300), Bureau of Reclamation, Denver, Colorado 80225; they will be comprehensively reviewed and incorporated as needed.

### **9.1.5 Applicability**

The procedures and recommendations in this chapter are applicable to the analysis and design of earth and rockfill dams founded on either dense soil or rock.

## **9.2 Embankment Deformations**

### **9.2.1 Causes of Deformations**

Embankment deformations under static loading occur as a result of volumetric changes, lateral spreading, or shear displacements within the embankment and foundation materials. Volumetric changes are due to either an increase in the normal stresses on a soil element causing a decrease in void volume or dilation of soil elements undergoing shear. Lateral spreading and shear displacements are due to squeezing, distorting, and localized shear failures of material elements as the materials adjust to the stress conditions imposed by constructing the embankment and operating the reservoir. The rate at which these deformations occur depends on the dissipation rate of excess pore pressures and the rate at which steady-state seepage conditions develop.

### **9.2.2 Factors Controlling Deformations**

Magnitudes and directions of embankment deformations are controlled by foundation and embankment material properties, abutment and embankment geometry, type of construction equipment used and embankment placement rates, reservoir loading conditions, and stress distribution within the various zones or layers within the embankment and its foundation. Other than removal, which is not always feasible, the designer has little control over the factors related to the foundation materials. On the other hand, the designer has a great deal of control over the factors related to the embankment. Therefore, these factors must be



recognized during site investigations, and features of the embankment must be designed to accommodate the given foundation conditions.

Material properties that control deformations are gradation, mineralogy, particle shape, particle arrangement, moisture content, and density. Within the foundation, these factors are the result of the geologic origin of the materials and history of the site. Within the embankment, these factors are controlled by the designer to the extent that suitable construction materials are located within a reasonable distance of the dam site and proper construction control is exercised in the borrow operation, embankment construction, and equipment used.

Geometric factors that influence embankment deformations include valley shape, abutment discontinuities, embankment zoning, and location of appurtenant structures. Control of these factors is greatly influenced by site selection and design features. Shaping of abutments; providing for filters, drains, and transition zones; flattening of embankment slopes; widening of embankment zones; and relocation of structures off of the embankment entirely are defensive design measures to accommodate geometric factors.

Construction factors related to deformations include moisture and density control, equipment types, and construction sequence and rates. By specifying the material gradation, placement moisture content, required density, equipment weights, and compaction procedures, the designer may control many material properties within the embankment. The rate of construction becomes critical when materials have become compressed to full saturation. Once saturation has been achieved within materials of low permeability, the rate of construction has a great deal of influence over the degree of excess pore pressures developed and, therefore, on the stability of the embankment and the construction and post-construction consolidation and lateral spread that occurs. Construction sequence in closure sections and on abutments are often useful tools to minimize the effects of deformations.

Three reservoir loading conditions that influence deformations are first filling, normal operational cycling, and rapid drawdown. During first filling, it is common for the crest of a dam to deform slightly in the upstream direction and for significant settlements to occur in upstream rockfill shells. As the phreatic surface develops within the embankment, consolidation of the embankment may slow or stop depending on the relative magnitudes of construction-induced pore pressures and pore pressures induced by high-level steady-state seepage conditions. During the development of the phreatic surface, most embankment crests will tend to move in a downstream direction. While these movements are noticed on most embankment dams, they are generally of negligible magnitude and consequence and are not calculated for design purposes.

Stress level and distribution within the foundation and embankment has a large impact on the deformations of the embankment. However, in situ stresses within

## **Design Standards No. 13: Embankment Dams**

the foundation are rarely known with any degree of accuracy, and methods for predicting the degree of stress transfer between various zones of an embankment or an embankment and its foundation are subject to debate. For these reasons, when vertical settlement calculations are performed, a conservative stress distribution is necessary. A one-dimensional vertical stress distribution (which ignores load transfer between hard and soft zones, fill and rockfill, and structures) is generally assumed to be conservative. However, the designer should be aware of potential problems with this assumption and consider that unusual cases may warrant more advanced analysis.

### **9.2.3 Effects of Deformations**

The major effects of deformations are loss of freeboard, damage to appurtenant structures located within or upon the dam, loss of confidence in the dam due to swayback appearance, cracking of the embankment (most detrimental to the impervious core), development of localized zones susceptible to hydraulic fracturing, and failure of instrumentation. The effects of deformation can usually be mitigated by designing features based on experience gained from studying historical performance of existing dams without the need for performing any elaborate analyses. For most situations, simple “rules of thumb” and/or basic settlement calculations to determine the amount of over-build or camber to place on top of a dam and settlement estimates for appurtenant structures yields satisfactory results. Detailed attention to embankment zoning and foundation shaping can minimize differential settlements, thereby reducing the potential for cracking of the core or development of zones susceptible to hydraulic fracturing. For any large or hazardous dam, the designer should assume some cracking of the core is inevitable, and filters and drains must be incorporated into the design to control seepage and prevent movement of material. The determining factors for performing additional analyses lie in the potential for cost savings when the “rule of thumb” and/or simple settlement calculation approach suggests excessive design requirements.

### **9.2.4 Patterns of Deformations**

The general pattern of deformations of embankment dams is shown on figures 9.2.4-1 through -3. From these figures, it can be seen that, for the maximum section of the dam, the general pattern of deformations for the upstream surface is down and upstream, while the downstream surface moves down and downstream. On the other hand, the crest of the dam moves down and upstream during first filling and down and downstream as reservoir water begins to penetrate the dam. Surface movements at the abutments contain an additional horizontal component of movement into the valley. Furthermore, along any vertical line drawn through the dam at any point, the distribution of deformations at the end of construction is roughly parabolic, and post-construction settlements result in a shift in this distribution at the dam crest. The shift remains almost constant to an approximate

elevation where the weight of fill above this elevation is sufficient to drive the material to saturation. Below this elevation, the amount of shift gradually reduces to a value of zero at the foundation contact. The post-construction shift in settlement is primarily due to the dissipation of excess pore pressures developed within the dam during construction. The post-construction shift in horizontal movements is mostly due to embankment material elements adjusting to the newly imposed stress distribution.

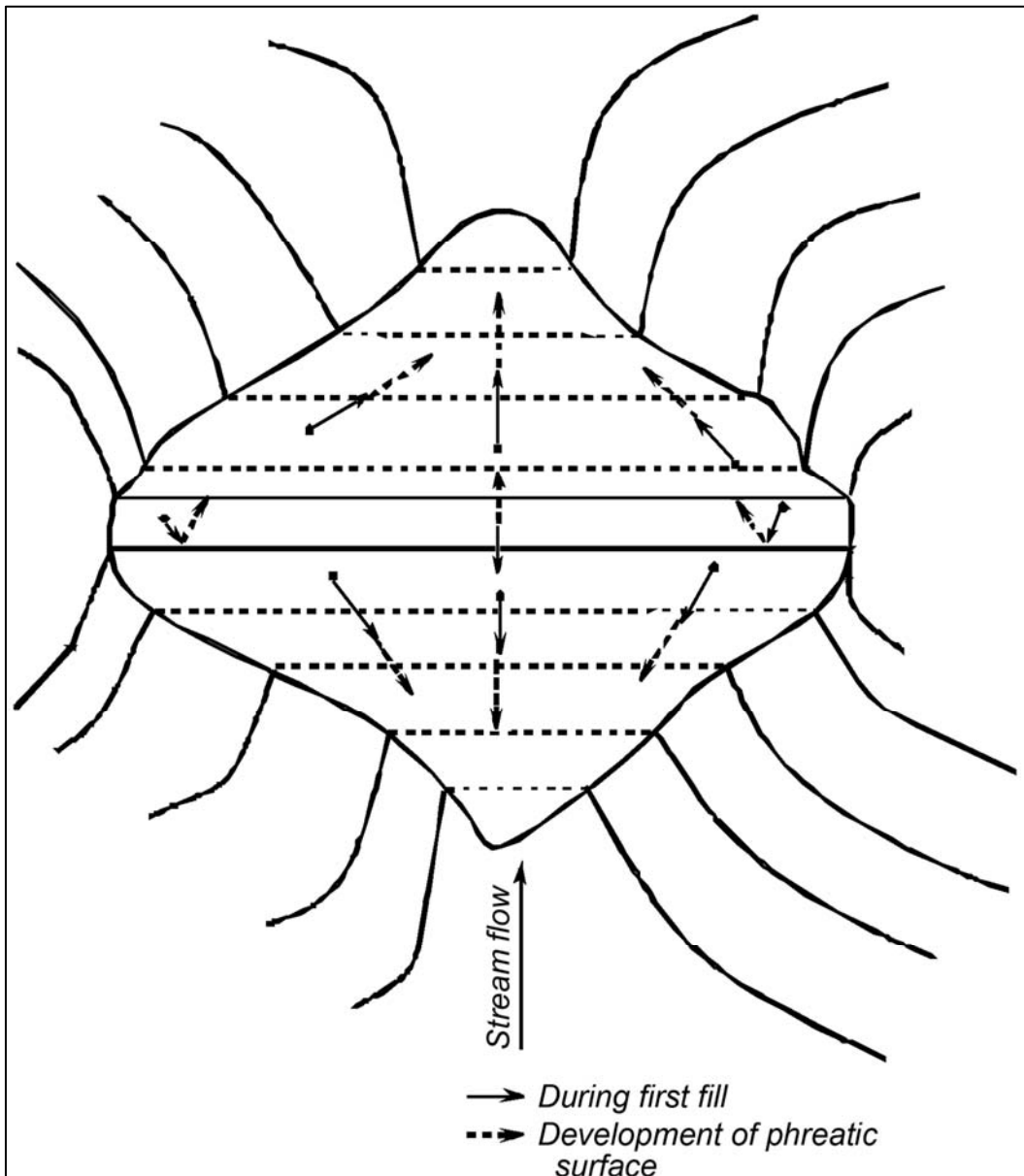

Figure 9.2.4-1. Generalized pattern of horizontal surface deformations of an embankment dam.

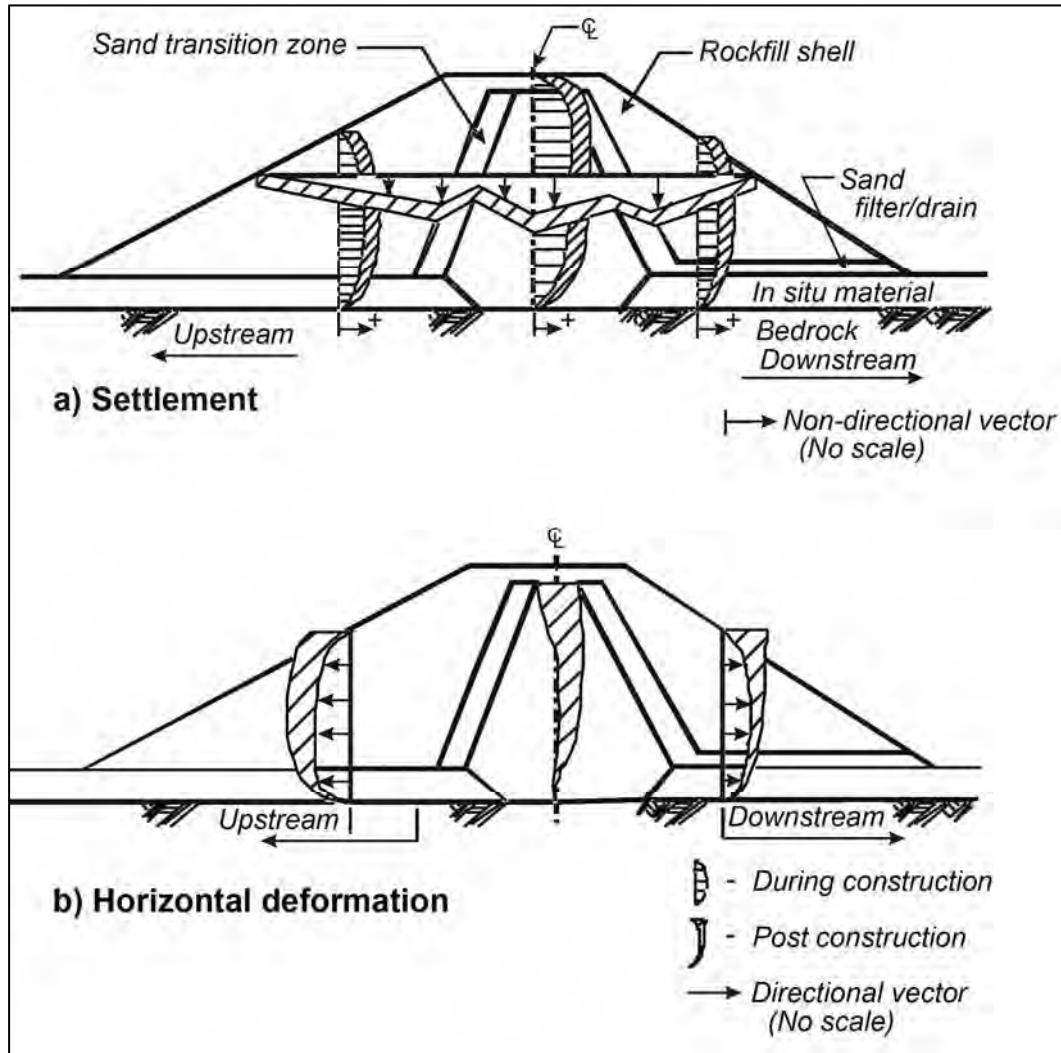

Figure 9.2.4-2. Generalized pattern of movements along maximum section of an embankment dam.

The magnitudes of horizontal deformations (into and down valley) are relatively small compared to the vertical settlement. The exact ratio between the magnitudes varies with geometry, dam zoning, and material properties. In practice it is common to analyze the vertical settlement and assume that if the settlements are in an acceptable range then the horizontal displacements will also be acceptable. This assumption is only valid so long as careful attention is given to foundation shaping, strength of foundation and embankment materials, and embankment zoning.

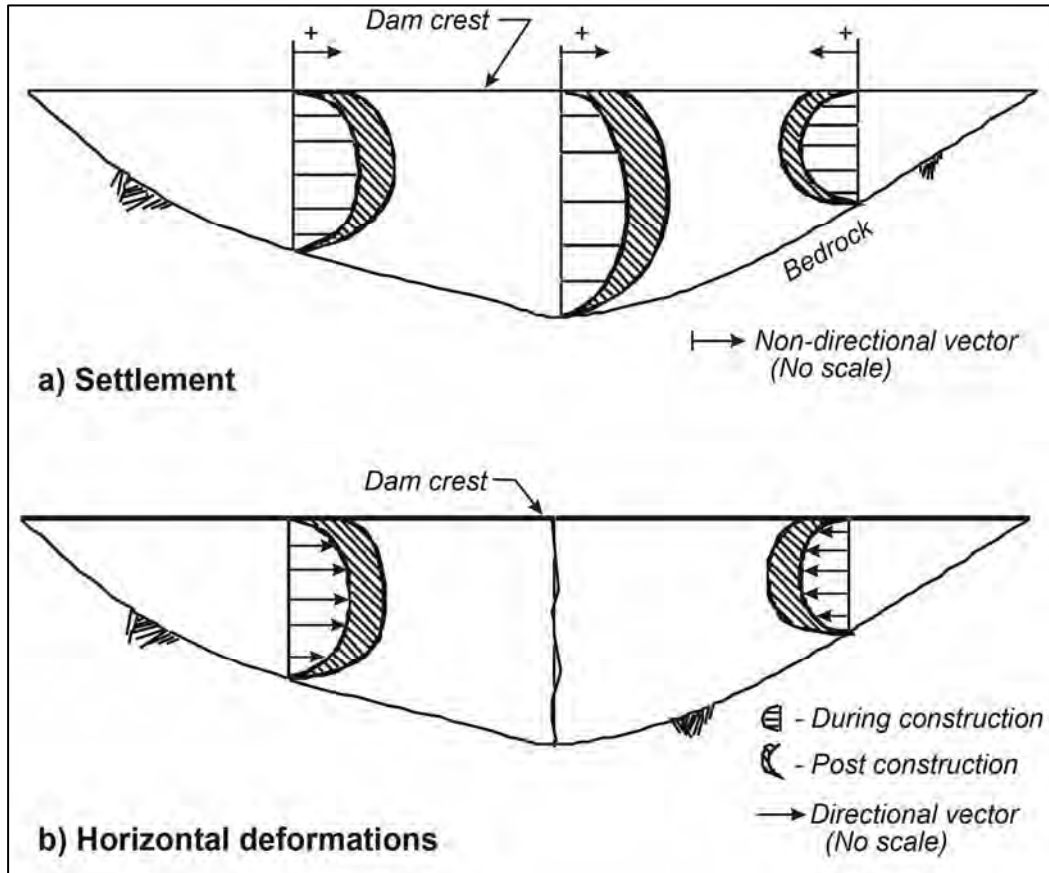

Figure 9.2.4-3. Generalized pattern of movements along centerline of an embankment dam.

## 9.3 Estimating Embankment Deformations

### 9.3.1 Need

The degree of analysis performed on an embankment is highly dependent on the design detail under consideration. For camber design, it is only necessary to estimate the amount of vertical settlement of the embankment crest. Often this estimate can be performed by applying simple guidelines that have been developed from observations of existing embankments. When cracking of the impervious core is of major concern or particularly compressible embankment or foundation materials are present, it is normal practice to perform some basic settlement calculations in order to decide whether a more complex analytical study needs to be performed or whether to simply incorporate more defensive design features. It is desirable to locate appurtenant structures or, for that matter, any structure off of the embankment. When possible, spillways and outlet works should be located through or over abutments or reservoir rim. If structures must be located on the embankment, settlement calculations are necessary. For the

## Design Standards No. 13: Embankment Dams

design of appurtenant structures, such as outlet works bridges, which may have some piers or footings founded on the embankment and some founded on rock, the guidelines used to estimate settlements of shallow footings located near the crest of the dam are the same as for determining dam camber design. For structures buried within the embankment, basic one-dimensional settlement calculations are generally sufficient. For structures located near the toe of the dam, lateral deformations can be estimated from relevant experience, but often requires advanced analytical or numerical analysis.

### 9.3.2 Procedures

Instrumentation data presented in the literature [1, 2, and 3] and on file at the Bureau of Reclamation for compacted embankments constructed on stiff foundations using modern equipment and designed according to Reclamation standards indicate post-construction crest settlements generally range between 0.2 and 0.4 percent and seldom exceed 0.5 percent of the embankment height. Based on this performance history, a “rule of thumb” for conservative camber design using 1.0 percent of the embankment height has become common practice [4]. For many low-risk dams or dams of less than 200 feet (60 m) in height, this “1 percent rule” is the only deformation estimate necessary to arrive at a satisfactory design for crest camber.

For moderate- to high-risk dams or dams exceeding 200 feet (60 m) or dams on compressible foundations, the “1 percent rule” alone is often considered insufficient analytical treatment of the deformation problem beyond preliminary camber design. Given the recent advances in mathematical computing power, the first impulse of many analysts is to perform a numerical model study; however, these studies are both time consuming and expensive to perform. For these reasons and others associated with material modeling and selection of boundary conditions, it is advisable to first perform a conservative and rather inexpensive one-dimensional (1-D) settlement analysis. The 1-D analyses presented in this chapter will yield no information on tensile stresses that can cause cracking, but the results are useful in determining whether or not excessive differential settlements within the embankment are a potential problem and provide a convenient cross check to determine the applicability for the “1 percent rule” in camber design. If the 1-D analysis indicates excessive differential settlements are a potential problem, then a choice may be between defensive design measures or advanced analyses. The main concern of differential settlement is that it may result in cracking or hydraulic fracturing, either of which could lead to internal erosion. Because properly designed and located filters and drains should be included in all important dams to protect against cracking and material movement, there may be no real need for advanced analyses.

There are cases that may warrant advanced analyses. These special cases include:

- a. Soft and deep soil foundations, particularly when overlying varying elevation bedrock surfaces.
- b. Essentially homogeneous clay embankments where high moisture contents in the fill cannot be avoided.
- c. Very precipitous or uniquely shaped abutments.
- d. Hard structures that penetrate or underlay the embankment and particularly if they are founded on a soft foundation, are unusually large, or unusually configured in relation to embankment height and configuration.
- e. Foundations that have significantly variable materials in either longitudinal or transverse directions.

There is also considerable merit in performing advanced analyses, comparing the results with actual behavior and publishing the information to advance the state of the art.

The 1-D analyses may be performed using one of three methods. First, a log-linear relationship (semi-log plot) between vertical stress and axial strain, respectively, may be developed for the various embankment materials from laboratory tests and for foundation materials using a variety of laboratory or in situ test methods. Second, the stress-strain plots of odometer tests performed on specimens of the various foundation and embankment materials may be used directly to determine the settlements. And third, for embankment materials, a parabolic equation of settlement distribution may be used. All three of these methods are presented in detail in appendix A. The method chosen for any particular analysis depends on whether post-construction settlements or differential settlements are of most concern. For example, if camber design is being studied, then methods one or two should be used. Whereas, if differential settlements within the embankment are the major concern, then method three is appropriate for the embankment material, and either method one or two is appropriate for the foundation materials. The advantage of method three over methods one and two is that settlements at various elevations within the embankment may be more rapidly estimated. The disadvantage of using method three is that post-construction crest settlements cannot be determined with this method.

In situations involving highly compressible foundation and/or embankment materials or unique design and/or construction features where the “1 percent rule” and 1-D analyses procedures appear to be inadequate, a thorough review of related literature and detailed discussions with experienced designers should be

pursued. A number of advanced analyses have been made of generalized problems and the results published, which can provide designers considerable insight to a problem. Once the designer is fully knowledgeable in the uniqueness of the problem and has determined that the need exists for a finite element analysis, the designer should have gathered enough background information to ensure that the proper procedure is used. For rare instances in which newly developed finite element codes are proposed for use, the designer should request to see the results of comparative physical tests and analytical predictions in order to develop confidence in the results from that analytical procedure. These physical tests may involve some form of back analysis of a similar embankment, constructing a test embankment at the proposed site, or centrifuge modeling of the most important features of the proposed embankment and foundation. For additional information on various finite element programs for predicting the behavior of an embankment dam, see references [5] and [6] and the supplemental references.

## **9.4 Defensive Design Measures**

### **9.4.1 Limiting Deformations**

There are essentially five means for limiting embankment deformations:

1. Foundation materials that are undesirable may be removed and replaced with more suitable materials.
2. Avoid using weak (compressible) materials within the embankment.
3. Undesirable materials, which cannot be removed from the foundation or which must be incorporated into the embankment, may be treated to enhance their performance.
4. The weak materials may be buttressed.
5. The weak materials may be reinforced.

Material removal and replacement is generally the preferable option for weak foundation materials as this ensures controlled treatment of the suspect material. This approach may include removing the weak materials and importing stronger materials or simply removing and compacting the removed material to a higher density. This approach is generally feasible so long as the foundation materials are of a shallow extent.

In order to avoid using weak materials within an embankment, the undesirable materials must be identified during borrow area investigations, and alternate sources of more desirable material must be located.



Foundation and embankment materials may be treated to enhance their performance in a variety of ways. Granular materials within the foundation may be compacted in place using dynamic compaction or they may be stiffened through cement grout injection techniques. Finer grained materials may be removed from the foundation or embankment borrow areas and mixed with coarser grained materials to form a more suitable fill. On rare occasions, materials may be chemically treated to alter their natural properties.

When weak foundation materials are of such depth or extent that removal or treatment techniques are not feasible, the most common practice is to buttress the weak materials. Buttressing of foundation materials is generally accomplished with low berms placed over the weak material to confine them in place. When weak embankment materials must be used in the construction of the dam, the materials may be buttressed by using wider/flatter stability shells.

Artificial reinforcement of weak embankment materials may be performed through the use of synthetic fabrics or placement of reinforcing strips within the weak material. Weak foundation material may be reinforced with the insertion of piles and/or the placement of synthetic fabrics on the foundation surface. Artificial reinforcement of weak materials is not currently in widespread use on large dams within Reclamation; however, this could change as more experience is gained in the long-term performance of these techniques.

One of the most important aspects of various measures to limit or control deformation is the economic comparison of alternatives. Configuration of the site, types of materials in the foundation, and types and location of borrow materials must be considered. It may be cheaper to flatten the slopes than to haul better material a longer distance. Deformations of weak foundations can be limited or mitigated by preloading, staged construction, and induced enhancement of drainage rates. Advanced analyses are often desirable to guide the staging and placement rates and to assist in monitoring behavior during construction.

### 9.4.2 Accepting Deformations

In cases where deformations that may cause cracking of the impervious core are unavoidable, the prudent course of action is to incorporate design features within the dam to mitigate the effects of cracking. Design features such as wider cores, use of higher plasticity clays that have better resistance to erosion and/or increased moisture contents in critical areas, wider downstream filter and drainage zones, and upstream “crack stopper” sand zones have all been employed on various dams. Other means of mitigating the effects of deformations are to (1) establish a construction sequence that allows the deformations to occur in stages and (2) preload the foundation in conjunction with enhanced foundation drainage features in order to force foundation deformations to occur before the

embankment is constructed. All of these defensive measures are acceptable practice provided good judgment is used.

## **9.5 Performance Monitoring**

### **9.5.1 Purpose**

The purpose for performance monitoring is twofold. First, the designer should follow through on the performance of the structure to ensure the actual behavior is within the established tolerable limits and that it is safely performing its intended function. Second, performance monitoring of existing structures helps provide the basis for developing improved design and construction procedures and enhancing engineering judgment.

The significant problem in performance monitoring is to determine the tolerable limits. Vertical movements can be estimated with some success using simple analyses as presented in this chapter. Estimating lateral deformation generally requires more advanced analyses. Generally tolerable limits are based on engineering judgment and past experience with similar materials and embankments where performance was considered acceptable. Thus, references to published behavior such as in references [1], [2], and [3] are essential. Several additional references are included in the supplemental references.

### **9.5.2 Instruments**

Typical instrumentation to monitor embankment and foundation deformations include surface measurement points, base plates, inclinometers, shear strips, tiltmeters, bore-hole extensometers, liquid level gauges, and internal settlement devices. Photo 9.5.2-1 shows these instruments. Detailed information on instruments used on Reclamation dams is included in Chapter 11 – Instrumentation—of this design standard. Because of the wide variety of instruments currently available and the development of new devices, the selection of a particular device to measure displacements is best accomplished by a cooperative effort between the design engineer and an instrumentation specialist. The designer's role in instrumentation is to identify the locations and types of deformations that are of concern and work with the instrumentation specialist to select the proper instruments to monitor those deformations.

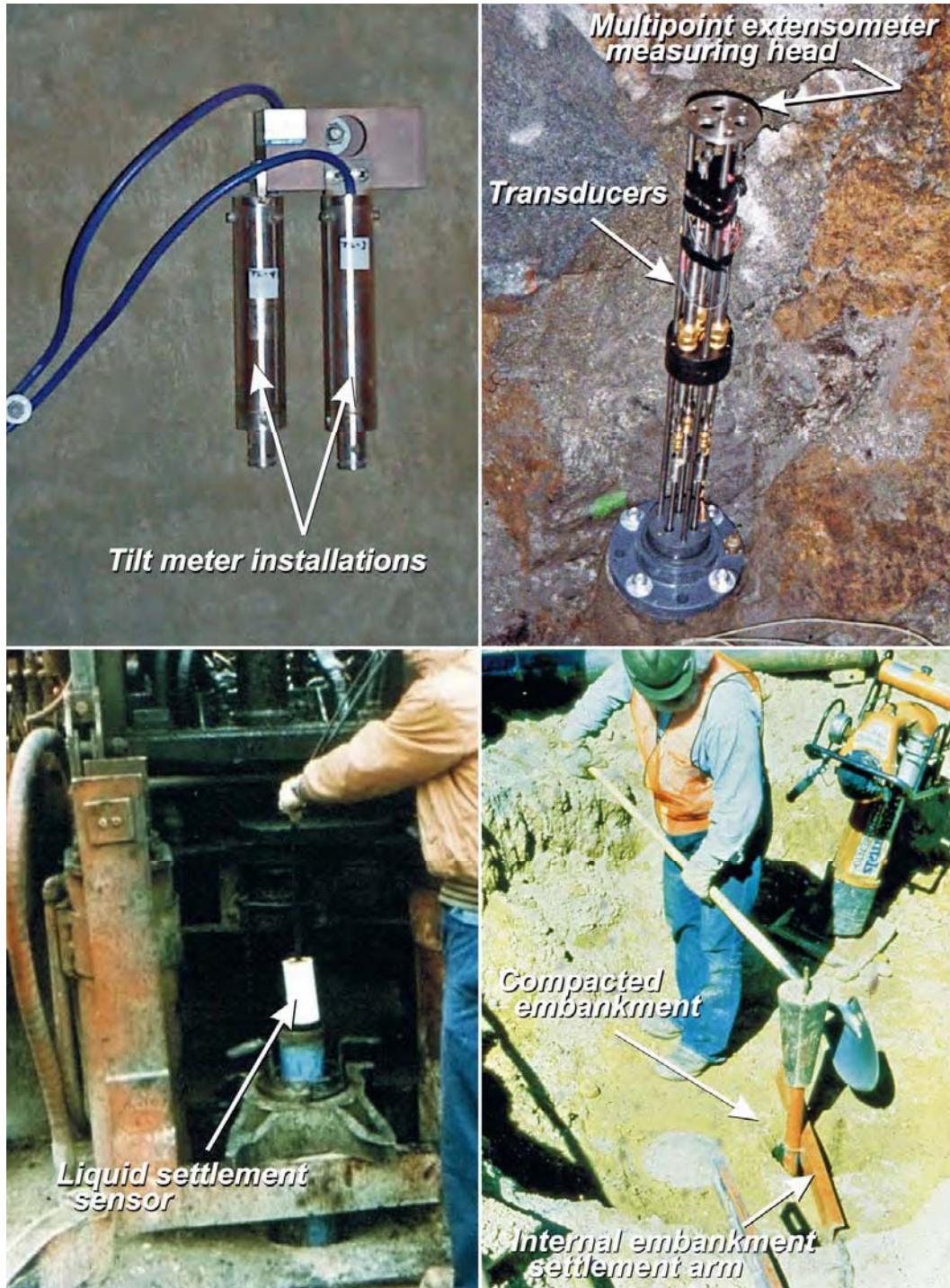
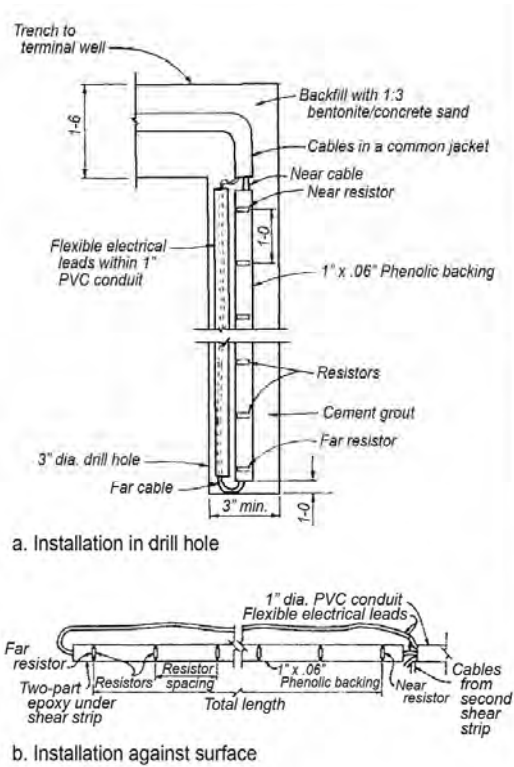

Figure 9.5.2-1. Typical instrumentation to monitor embankment foundation deformations.



**Design Standards No. 13: Embankment Dams**



**Shear Strip Installations**

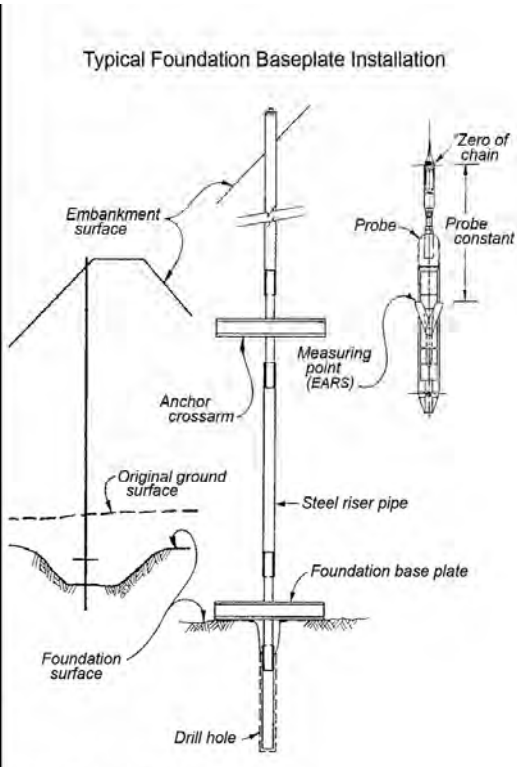

**Foundation Settlements**

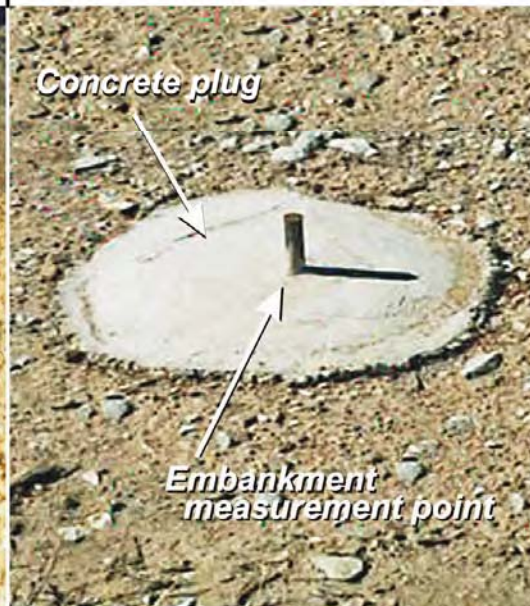
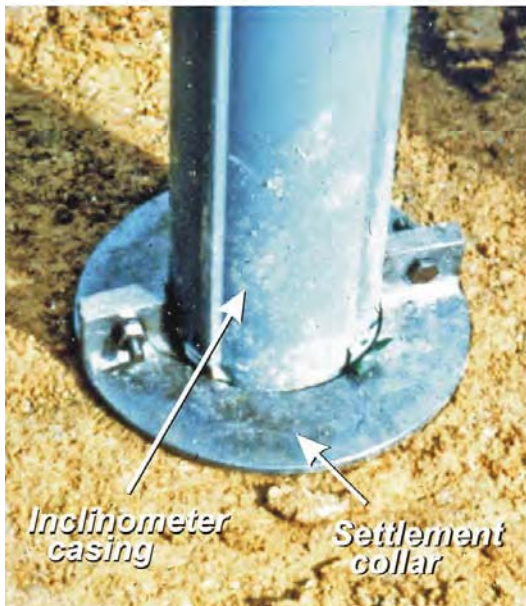

**Photo 9.5.2-1 (continued). Typical instrumentation to monitor embankment and foundation deformations.**

## 9.6 Existing Dams

For a properly designed and well-constructed dam in service, deformations under normal operations are generally within the design limits. However, if deformations observed via instrumentation or visual observations are found to be excessive, detailed investigations of site conditions and construction records, as well as instrumentation and monitoring procedures, need to be undertaken to understand the cause of unexpected deformation behavior. Excessive deformations could be due to, or lead to, seepage-related internal erosion, which could have serious consequences if left unattended. Each dam with unusual deformations under normal operating conditions needs to be investigated and appropriately remediated under the guidance of experienced dam designers.

Basic requirements for satisfactory performance and design that apply to a new dam also apply to the design of modifications for existing dams. Static deformations of modifications should be assessed as a part of required analyses for the design of modifications to existing dams.

## 9.7 Additional Information

Supplemental references included in the references contain useful information of interest on deformations of embankment dams. Examples of detailed settlement analyses related to embankment dams are included in appendix B.

## 9.8 References

- [1] Sherard, James L., Richard J. Woodward, Stanley F. Gizienski, and William A. Clevenger, *Earth and Earth Rock Dams*, John Wiley and Sons, New York, NY, 1963.
- [2] Wilson, Stanley D., “Deformation of Earth and Rockfill Dams,” *Embankment-Dam Engineering*, Casagrande Volume, John Wiley and Sons, New York, NY, pp. 365-417, 1973.
- [3] Gould, James P., Technical Memorandum 648, “Compression Characteristics of Rolled Fill Materials in Earth Dams,” U.S. Department of the Interior, Bureau of Reclamation, Denver, CO, 1954.
- [4] *Design of Small Dams*, 3rd edition, U.S. Department of the Interior, Bureau of Reclamation, Denver, CO, 1987.

## **Design Standards No. 13: Embankment Dams**

- [5] Naylor, D.J., “Static Analysis of Embankment Dams: A Finite Element Perspective,” *Dam Engineering*, Volume I, Issue 2, Reed Business Publishing Group, Surrey SM2 5AS UK, 1990.
- [6] Woodward-Clyde Consultants, Report for Contract No. 8-CA-30-06170, Subject: “Property Characterization of Zone 1 Core Material and Deformation Analyses, New Waddell Dam, Phoenix, Arizona,” U.S. Department of the Interior, Bureau of Reclamation, Denver, CO, 1989.
- [7] Perloff, William H., “Pressure Distribution and Settlement,” *Foundation Engineering Handbook*, Van Nostrand Reinhold Company, New York, NY, pg 148-196, 1975.

### **9.8.1 Supplemental References**

#### **Use of FEM Analysis in Construction Monitoring**

- Walker, Willis L., and J. Michael Duncan, Lateral Bulging of Earth Dams, ASCE, *J. Geotech. Engr.*, July 1984.
- Soriano, A., J.M. Duncan, K. Wong, and J.M. Simon, Finite Element Analyses of Stresses and Movements in Birch Dam, Contract Report No. TE-75-2, University of California, Berkeley, 1975.

#### **Deformation of Rockfill Dams**

- Clements, Ronald P., Post-Construction Deformation of Rockfill Dams, ASCE, *J. Geotech. Engr.*, July 1984.
- Dascal, Oscar, Post-Construction Deformations of Rockfill Dams, ASCE, *J. Geotech. Engr.*, January 1987.

#### **General Deformation References**

- Sherard, James L., Hydraulic Fracturing in Embankment Dams, ASCE, *J. Geotech. Engr.*, October 1986.
- Jansen, Robert B., *Advanced Dam Engineering*, Van Nostrand Reinhold, New York, 1988.
- Corps of Engineers, *Earth and Rockfill Dams General Design and Construction Considerations*, EM 1110-2-2300, March 1971.

Sherard, J.L., Trends and Debatable Aspects in Embankment Dam Engineering, *Water Power and Dam Construction*, December 1984.

Holtz, Robert D. and William D. Kovacs, *An Introduction to Geotechnical Engineering*, Prentice-Hall, Englewood Cliffs, NJ, 1981.

Chugh, Ashok K. and Luther W. Davidson, Analysis of foundation settlements at Ridgway Dam, *Canadian Geotechnical Journal*, Vol. 25, pp. 716-725, 1988.

### Generalized FEM References

Casagrande, A., and S.W. Covarrubias, Cracking of Earth and Rockfill Dam, U.S. Army Corps of Engineers (WES), Contract Report No. 5-70-7, Vicksburg, Mississippi, July 1970.

Lefebvre, G. and J.M. Duncan, Three-Dimensional Finite Element Analyses of Dams, U.S. Army Corps of Engineers (WES), Contract Report No. 5-71-6, Vicksburg, Mississippi, May 1971.

Lefebvre, G. and J.M. Duncan, Finite Element Analyses of Transverse Cracking in Low-Embankment Dams, U.S. Army Corps of Engineers (WES), Contract Report No. 5-74-3, Vicksburg, Mississippi, October 1974.

Kulhawy, F.H., J.M. Duncan, and H. B. Seed, Finite Element Analyses of Stresses and Movements in Embankments During Construction, U.S. Army Corps of Engineers (WES), Contract Report No. 5-69-8, Vicksburg, Mississippi, November 1969.

Nobari, E.S., and J.M. Duncan, Effect of Reservoir Filling on Stresses and Movements in Earth and Rockfill Dams, U.S. Army Corps of Engineers (WES), Contract Report No. 5-72-2, Vicksburg, Mississippi, January 1972.

Nobari, E.S., K.L. Lee, and J.M. Duncan, Hydraulic Fracturing in Zoned Earth and Rockfill Dams, U.S. Army Corps of Engineers (WES), Contract Report No. 5-73-2, Vicksburg, Mississippi, January 1973.

Chirapuntu, S., and J.M. Duncan, The Role of Fill Strength in the Stability of Embankments on Soft Clay Foundations, U.S. Army Corps of Engineers (WES), Contract Report No. 5-76-6, Vicksburg, Mississippi, June 1976.





**Appendix A**

## **Example Problem**



# Introduction

The primary purposes of a deformation analysis are to (1) estimate settlements of the embankment in order to perform a camber design, (2) determine if there are areas where potential cracking of the impervious core may occur, and (3) estimate displacements of appurtenant structural components located on the embankment. Therefore, the example in this appendix was developed to illustrate the procedures used to arrive at a conservative settlement estimate and evaluate the need for more elaborate analytical analyses. The dam presented in this example was developed to illustrate the calculation methods. Simplification of the basic design of the dam and its foundation were deemed appropriate in order to stress the calculation process rather than examine the minute design details of an actual dam. Examples of settlement analyses related to three real dams are included in appendix B; additional examples of settlement analyses can be found in Bureau of Reclamation files.

## Discussion

### Geometry

The dam used in this example is shown on figure A-1. For the calculation methods presented in this appendix, the slopes of the upstream and downstream shells, as well as the core, are immaterial to the calculation process. The height of the dam is 225 feet from the bottom of the cutoff trench to the crest at the maximum section. A 25-foot thick layer of compressible impervious material was left in place in the foundation between the bottom of the cutoff trench and the top surface of the bedrock in order to illustrate the procedure for calculating foundation settlement. The compressible foundation material was divided into two layers (1F and 2F) with different compression characteristics. For this example, the bedrock has been assumed to be incompressible. The abutments and the foundation were shaped to form a uniformly varying surface with no irregularities, overhangs, or sudden discontinuities.

### Deformation Modulus and Stress Distribution

This example illustrates a simple logical approach to settlement analysis. The assumptions used to develop the analysis reflect this intent. Experience with the performance of existing dams has shown that conservative estimates of both deformation modulus and stress distribution would lead to an uneconomical and overly conservative design; therefore, a constrained deformation modulus, a one-dimensional (1-D) stress distribution, and settlement calculations to time infinity are used in the analysis. A dam is by no means a 1-D structure nor is it expected to have an infinite life expectancy. These assumptions are simply made in order to counterbalance the effect of using a constrained modulus of deformation.

## Design Standards No. 13: Embankment Dams

Additional conservative assumptions in the analysis include using the wet unit weight of the material above the groundwater table to calculate effective stresses and assuming the effects of reservoir water penetrating the embankment and foundation soils will not decrease effective stress levels. The combined effect of these assumptions yields an analysis procedure that is considered appropriately conservative in most cases. Note that there can be considerable error in the analysis of a soft, thin, clay core supported by relatively rigid filters or shells. If more accuracy is needed, an advanced finite element analysis may be desirable.

Figure A-2 presents the relationship between an assumed 1-D stress distribution and the theoretical stress distribution at the base of an elastic embankment [7]. From this figure it can be seen that the 1-D stress distribution assumption is conservative along the centerline. For points near the toe of the embankment, this assumption is no longer conservative, but the difference is negligible due to the low embankment height in this area.

## Foundation Settlement Calculations

Foundation settlement calculations are needed primarily for the settlement design of river outlet structures and investigation of differential settlements of the embankment. For this example, a 25-foot thick layer of compressible material was left in the foundation at the maximum section. In order to calculate the embankment settlements induced by compression of this material, the slope of the recompression ( $C_{re}$ ) and virgin compression ( $C_{ce}$ ) lines for each material layer must be estimated. The terms  $C_{re}$ ,  $C_{ce}$ ,  $\sigma'_p$ ,  $\sigma'_{vo}$ , and  $\sigma'_{vf}$  used in this calculation are defined on figure A-3.

The general form of the equation for calculating layer settlements is [8]:

$$S_i = C_{re} \cdot H_o \cdot \log(\sigma'_p/\sigma'_{vo}) + C_{ce} \cdot H_o \cdot \log(\sigma'_{vf}/\sigma'_p) \quad (A.1)$$

where:

$S_i$  = The settlement of the layer

$H_o$  = The initial layer thickness

This general equation applies to an in situ soil element that is overconsolidated and will be loaded to a normally consolidated state once the embankment has been constructed. Three other possibilities exist for the stress path of a soil element. First, a soil may be overly consolidated in situ and remain so after construction is complete. Second, occasionally a soil element may be normally consolidated in situ and would remain so after construction. And third, very rarely a soil element is normally consolidated in situ, and due to excavation of loose undesirable material and placement of higher density acceptable material, the soil element ends up being overconsolidated. Since it is seldom that the

second and third alternative cases of stress path are encountered in the analysis of an embankment dam, only the reduction of the general form of the settlement equation for the first alternative case is presented. The reduced equation for an overconsolidated soil element that remains overconsolidated after the embankment has been constructed is:

$$S_i = C_{re} \cdot H_o \cdot \log(\sigma_{vf}'/\sigma_{vo}') \quad (A.2)$$

Calculations for the settlement of the foundation are presented in table A-1. Note that the post-construction settlements of the foundation were estimated at 25 percent of the total foundation settlements. This estimate was based on a review of embankment dams founded on relatively easily drained materials. The post-construction settlement of clay or silt portions of a foundation depend on the location of the water table, degree of saturation, location and distances to drainage faces, and time rates of construction loading. Consequently, if there are significant thicknesses of clay or silt in a foundation, the estimate of amount of post-construction settlement should be based on time rate of consolidation studies.

## Camber Design

The easiest and oftentimes the most practical method of camber design is to apply the “1 percent rule.” This method is illustrated in table A-2. In this method, 1 percent of the embankment height is calculated for various stations along the embankment. Then, the numbers are added to the post-construction foundation settlements to arrive at a required camber height. The actual camber design is arrived at by (1) rounding the calculations to the nearest 0.5 foot at the maximum section of the dam, (2) maintaining this elevation across the embankment section within the valley floor, (3) drawing straight lines from this section to the contacts between the ends of the dam and the abutments, (4) comparing this straight line approximation to the calculated required camber at selected stations, and (5) adjusting the lines as required to provide adequate camber across the dam. It is interesting to note that in this example, as it is often in real situations where competent foundation materials exist, that the computed post-construction settlements of the foundation are minimal compared to 1 percent of the embankment height.

For high risk dams, dams over 200 feet in height, or when an unusually compressible core material must be used in constructing the dam, it is advisable to perform a 1-D analysis to determine if the “1 percent rule” is still applicable. The additional assumptions that must be made for estimating post-construction settlements with a 1-D analysis are (1) compression of the embankment to achieve saturation of the material occurs during construction and (2) consolidation of the embankment due to the dissipation of excess pore pressures developed during

### Design Standards No. 13: Embankment Dams

construction occurs after construction has been completed. From basic soil mechanics it can be shown that the equation to determine the percent of axial strain required to achieve saturation in the odometer test is:

$$\varepsilon_a = V_a = \gamma_d \cdot (\omega_c/\gamma) \cdot (1/D_s - 1) \cdot 100 \quad (A.3)$$

where:

- $\varepsilon_a$  = The axial strain required to achieve saturation in percent
- $V_a$  = The volume of air in the specimen in percent at the beginning of the test
- $\gamma_d$  = The initial dry unit weight of the specimen
- $\omega_c$  = The initial moisture content of the specimen
- $\gamma$  = The unit weight of water
- $D_s$  = The initial degree of saturation of the specimen

The 1-D analysis can be performed by the same method as the foundation settlements were calculated above or by the method of directly applying the odometer test results stress-strain plot. In order to compute the post-construction settlements with a log-linear compression analysis, the total compression and compression to saturation of the embankment must be calculated. The difference between the total compression and the compression to saturation is assumed to be the post-construction settlement.

The alternative method of directly applying the odometer test results stress-strain plot is presented in its entirety in table A-3, columns (1) through (13). The complete procedure was presented in order to compare the results of this analysis with the results of the parabolic equation procedure presented later. For a check on the "1 percent rule," only columns (1) through (5) and column (7) need be completed. The post-construction settlement of the crest is the difference between the totals for columns (5) and (7). The results of an odometer test used to perform this analysis are shown on figure A-4. The basic steps for this procedure are (1) break the dam into layers and calculate the average stress in each layer (columns (1) through (3)), (2) pick the strain level corresponding to this stress level off of the stress-strain plot and calculate the total compression of the embankment (columns (4) and (5)), and (3) compute the strain level required to drive the embankment to saturation (equation (3)) and determine the amount of embankment compression that occurs during construction (column(7)). The purpose of columns (6) and (8) through (13) is to determine the vertical settlement profile at a specific dam section. The basics of this additional procedure are (1) determine the amount of compression that occurs in the dam prior to reaching the top elevation of each layer and (2) subtract this amount of compression from the total compression of the embankment occurring below this elevation. This compression subtraction procedure accounts for the fact that the compression occurring prior to reaching the top elevation of each layer is made up in an equal amount of embankment material required to achieve the top of layer elevation. The results of the settlement calculations are presented on figure A-5.

The procedure presented provides a vertical profile of settlement at a particular section. The process must be repeated at appropriate embankment sections to obtain a “settlement profile for the dam.”

## Cracking Potential Evaluation

As none of the 1-D methods for estimating post-construction settlements can predict locations of tensile stresses within an embankment, a much faster method of calculating settlement profiles is recommended for evaluating cracking potential. The method for evaluating cracking potential and the necessity to perform more elaborate analytical modeling is to assume a parabolic settlement distribution occurs within the embankment. The settlement distribution must be determined for a number of sections representing significant changes in foundation slope, embankment height, location of hard structure contacts, etc. The equation for this parabolic settlement calculation is:

$$S = (\gamma_w/E) \cdot (h - y) \cdot (y) / 144 \quad (4)$$

where:

- S = The settlement at a point within the dam
- h = The height of the dam
- y = The amount of fill beneath the point of interest
- E = The 1-D secant modulus to a stress level equivalent to the midheight of the dam

The results of the parabolic equation calculations for the example dam are presented in table A-4 and on figure A-5.

## Results

For this example problem, the post-construction settlements were calculated by the 1-D method to be slightly in excess of 1.0 percent. For camber design purposes, 1.0 percent of the embankment height would probably suffice. For cracking potential evaluation, it would be advisable, for this material, to assume cracking will probably occur near the ends of the dam and in areas where severe foundation discontinuities or steep abutment slopes exist and defensive design steps should be considered.

Geometry						Loading condition and material properties					Settlement			
Dam station	Original foundation thickness (ft)	Depth of excav. (ft)	Remaining foundation thickness (ft)	Layer No.	Layer thickness H <sub>o</sub> (ft)	C <sub>re</sub>	C <sub>ce</sub>	σ' <sub>p</sub> lb/in <sup>2</sup>	σ' <sub>vo</sub> (lb/in <sup>2</sup> )	σ' <sub>vf</sub> (lb/in <sup>2</sup> )	Equation No.	Layer settle S <sub>i</sub> (ft)	Total settle S <sub>t</sub> (ft)	Estimated settlement postconst. (ft)
0+00	0	0	0	-	-	-	-	-	-	-		0	0	0
1+00	15	0	15	1f	15	0.005	0.05	150	5.7	44.8	2	0.07	0.07	0.02
2+00	30	15	15	1f	15	.005	.05	150	19.9	91.6	2	0.05	0.05	0.01
3+00	40	20	20	1f	20	.005	.05	150	26.4	162.8	1	0.11	0.11	0.03
				2f	0	.001	.01	250	0	0	-	0		
4+00	50	25	25	1f	15	.005	.05	150	29.2	192.7	1	0.13	0.14	0.04
				2f	10	.001	.01	250	39.2	202.7	2	0.01		
5+00	50	25	25	1f	15	.005	.05	150	29.2	201.4	1	0.15	0.16	0.04
				2f	10	.001	.01	250	39.2	211.4	2	0.01		
6+00	40	15	25	1f	15	.005	.05	150	19.9	175.3	1	0.10	0.11	0.03
				2f	10	.001	.01	250	29.9	185.3	2	0.01		
7+00	30	15	15	1f	15	.005	.05	150	19.9	136.2	2	0.06	0.06	0.02
				2f	0	.001	.01	250	-	-	-	0		
8+00	20	10	10	1f	10	.005	.05	150	13.2	82.1	2	0.04	0.04	0.01
9+00	5	0	5	1f	15	.005	.05	150	3.8	29.2	2	0.02	0.02	0.01
10+00	0	0	0	-	-	-	-	-	-	-	-	-	0	0

Table A-1. Foundation settlement calculations



Table A-1. Foundation compression calculations - continued

Equation No.	Stress condition	Equation
1	Overconsolidated to normally consolidated	$S_i = C_{re} H_0 \log \frac{\sigma_p'}{\sigma_{v0}'} + C_{ce} H_0 \log \frac{\sigma_{vf}'}{\sigma_p'}$
2	Overconsolidated to overconsolidated	$S_i = C_{re} H_0 \log \frac{\sigma_{vf}'}{\sigma_{v0}'}$

Assumptions:

- 1)  $\gamma_w$  excavation = 135 lbf/ft<sup>3</sup>.
- 2)  $\gamma_{1f}$  = 110 lbf/ft<sup>3</sup>.
- 3)  $\gamma_{2f}$  = 125 lbf/ft<sup>3</sup>.
- 4) Postconstruction foundation settlement = 0.25  $S_t$ .
- 5)  $C_{re}$ ,  $C_{ce}$ , and  $\sigma_p$  for foundation materials are as shown in table A-1.

**Design Standards No. 13: Embankment Dams**

**Table A-2. Camber design by “1 percent rule”**

Dam station	Embankment height (ft)	1 percent of height (ft)	Postconst. foundation settlement (ft)	Camber (ft)
0+00	0	0	0	0
1+00	45	0.45	0.02	0.6
2+00	115	1.15	0.01	1.2
3+00	200	2.00	0.03	1.8
4+00	215	2.15	0.04	2.5
5+00	225	2.25	0.04	2.5
6+00	195	1.95	0.03	2.0
7+00	150	1.50	0.02	1.5
8+00	90	0.9	0.01	1.0
9+00	30	0.3	0.01	0.5
10+00	0	0	0	0

Notes:

1) Camber design is a series of straight lines between dam stations 0+00 and 4+00, stations 4+00 and 5+00, and stations 5+00 and 10+00.

2) The amount of postconstruction foundation settlement in this example is negligible compared to 1 percent of embankment height.

Table A-3. One-dimensional compression calculations

(1)	(2)	(3)	(4)	(5)	(6)	(7)	(8)	(9)	(10)	(11)	(12)	(13)
Layer No.	Layer thick (ft)	Average Stress* (lb/in <sup>2</sup> )	Vert. strain (%)	Total compress in layer (ft)	Total compress below top of layer (ft)	Compress of layer during const. (ft)	Compress below layer top during const. (ft)	Post-const. compress of layer (ft)	Compress prior to reaching layer top (ft)	Total settlement (ft)	Settle during const. (ft)	Post-const. settlement
1	25	10.9	0.2	0.05	10.43	0.05	7.80	0.00	7.80	2.63	0	2.63
2	25	32.6	0.8	0.20	10.38	0.20	7.75	0.00	6.55	3.83	1.20	2.63
3	25	54.3	2.0	0.50	10.18	0.50	7.55	0.00	5.30	4.88	2.25	2.63
4	25	76.1	3.2	0.80	9.68	0.80	7.05	0.00	4.05	5.63	3.00	2.63
5	25	97.8	5.0	1.25	8.88	1.25	6.25	0.00	2.80	6.08	3.45	2.63
6	25	119.6	6.0	1.50	7.63	1.25	5.00	0.25	1.55	6.08	3.45	2.63
7	25	141.3	7.2	1.80	6.13	1.25	3.75	0.55	0.75	5.38	3.00	2.38
8	25	163.0	8.3	2.08	4.33	1.25	2.50	0.83	0.25	4.08	2.25	1.83
9	25	184.8	9.0	2.25	2.25	1.25	1.25	1.00	0.05	2.20	1.20	1.00
Total				10.43		7.80		2.63				

\*  $\gamma_w = 125 \text{ lb/ft}^3$ .

**Design Standards No. 13: Embankment Dams**

**Table A-3. One-dimensional compression calculations - continued**

Col(3):

$$\text{Col}(3)_i = 1/2 \gamma_w \text{Col}(2)_i \frac{1}{144}$$

$$\text{Col}(3)_i = \left[ \gamma_w \text{col}(2)_i \frac{1}{144} \right] + \text{col}(3)_{i-1}$$

Col(4):

Taken from consolidation plot (fig. A-4)

Col(5):

$$\text{Col}(5)_i = \text{Col}(2)_i \cdot \text{Col}(4)_i / 100$$

Col(6):

$$\text{Col}(6)_j^n = \sum_{i=j}^n \text{col}(5)_i + \text{Col}(5)_i$$

for j = 1

Col(7):

for  $\text{Col}(5)_i < 1.25$ ;  $\text{Col}(7)_i = \text{Col}(5)_i$

for  $\text{Col}(5)_i \geq 1.25$ ;  $\text{Col}(7)_i = 1.25$

where 1.25 ft = compression required for the 25-ft layer to reach 100 percent saturation

Col(8):

$$\text{Col}(8)_j^n = \sum_{i=j}^n \text{col}(7)_i$$

for j = 1

Col(9):

$$\text{Col}(9)_i = \text{Col}(5)_i - \text{Col}(7)_i$$

Col(10):

$$\text{Col}(10)_j^n = \sum_{i=1}^{n-(j-1)} \text{col}(7)_i$$

for j=1

Col(11):

$$\text{Col}(11)_i = \text{Col}(6)_i - \text{Col}(10)_i$$

Col(12):

$$\text{Col}(12)_i = \text{Col}(8)_i - \text{Col}(10)_i$$

Col(13):

$$\text{Col}(13)_i = \text{Col}(11)_i - \text{Col}(12)_i$$

Note: For camber design check, only columns (1) through (5) and column (7) need be completed.

**Table A-4. Embankment settlements by parabolic equation**

Fill height beneath point y (ft)	Settlement S (ft)
225	0
200	2.17
175	3.80
150	4.89
125	5.43
100	5.43
75	4.89
50	3.80
25	2.17
0	0

Equation: 
$$S = \frac{\gamma_w}{E_{50}}(h - y)(y)\left(\frac{1 \text{ ft}^2}{144 \text{ in}^2}\right)$$

where:

$$\gamma_w = 125.2 \text{ lbf/ft}^3$$

$$h = 225 \text{ ft}$$

$$E = \frac{100}{0.05} = 2,000$$

Note:  $\gamma_w$ , h, and E are taken from consolidation plot, figure A-4.

**Design Standards No. 13: Embankment Dams**

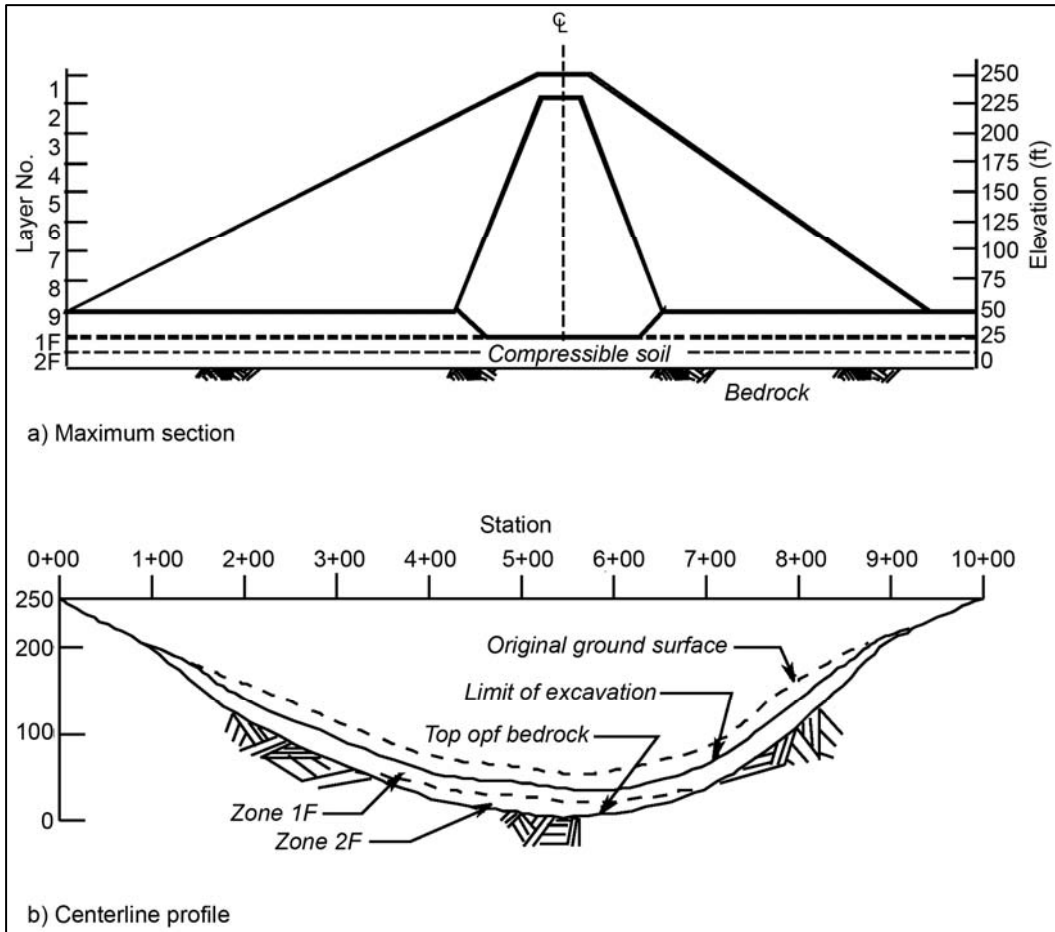

**Figure A-1. Example dam.**

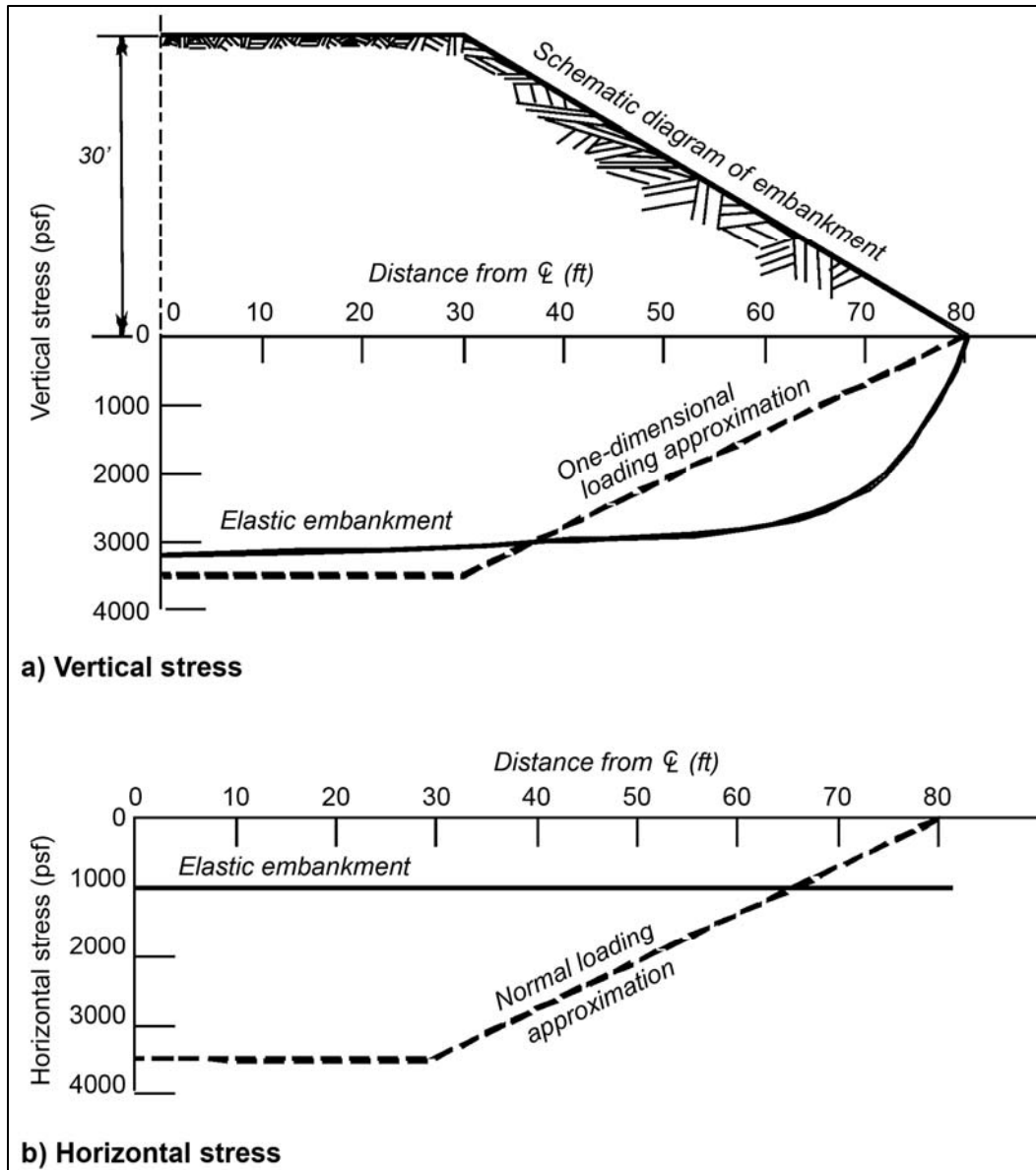

Figure A-2. Stress distribution on the base of an elastic embankment [7].

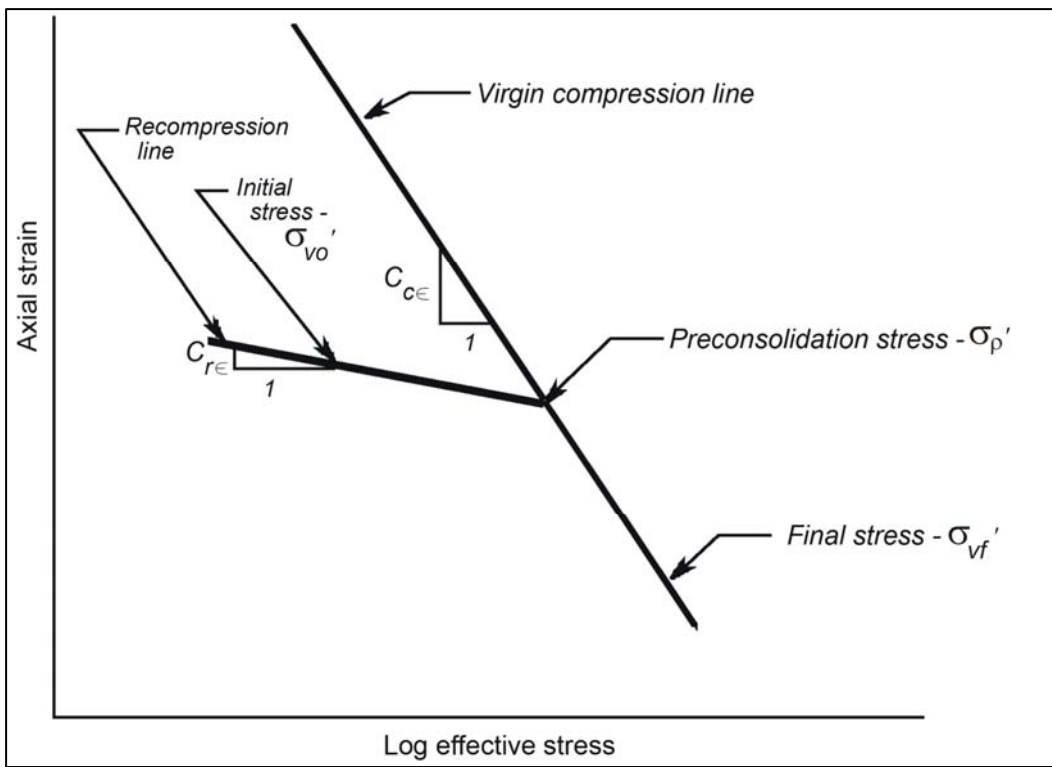

Figure A-3. Theoretical one-dimensional compression curve for a soil element.



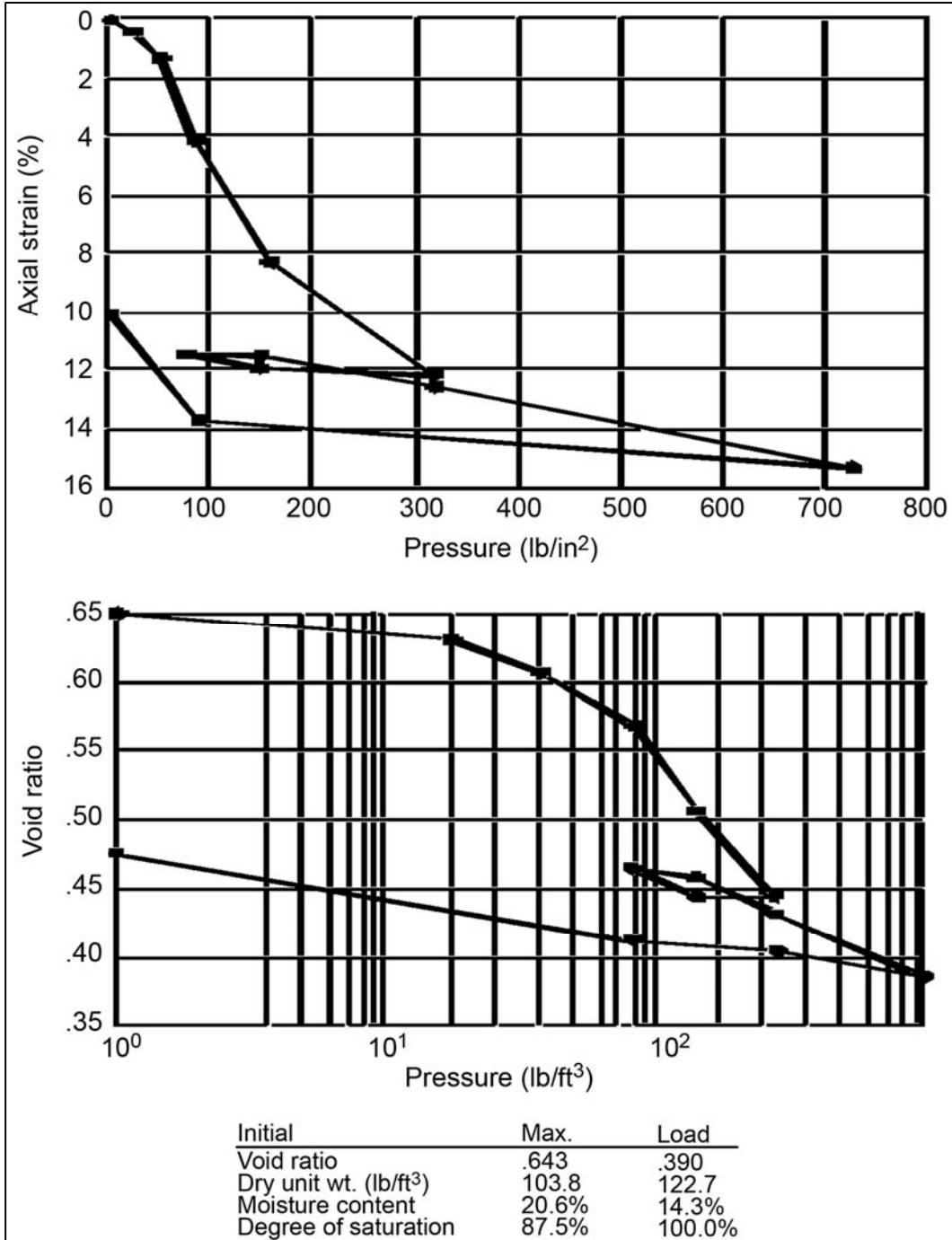

Figure A-4. One-dimensional consolidation

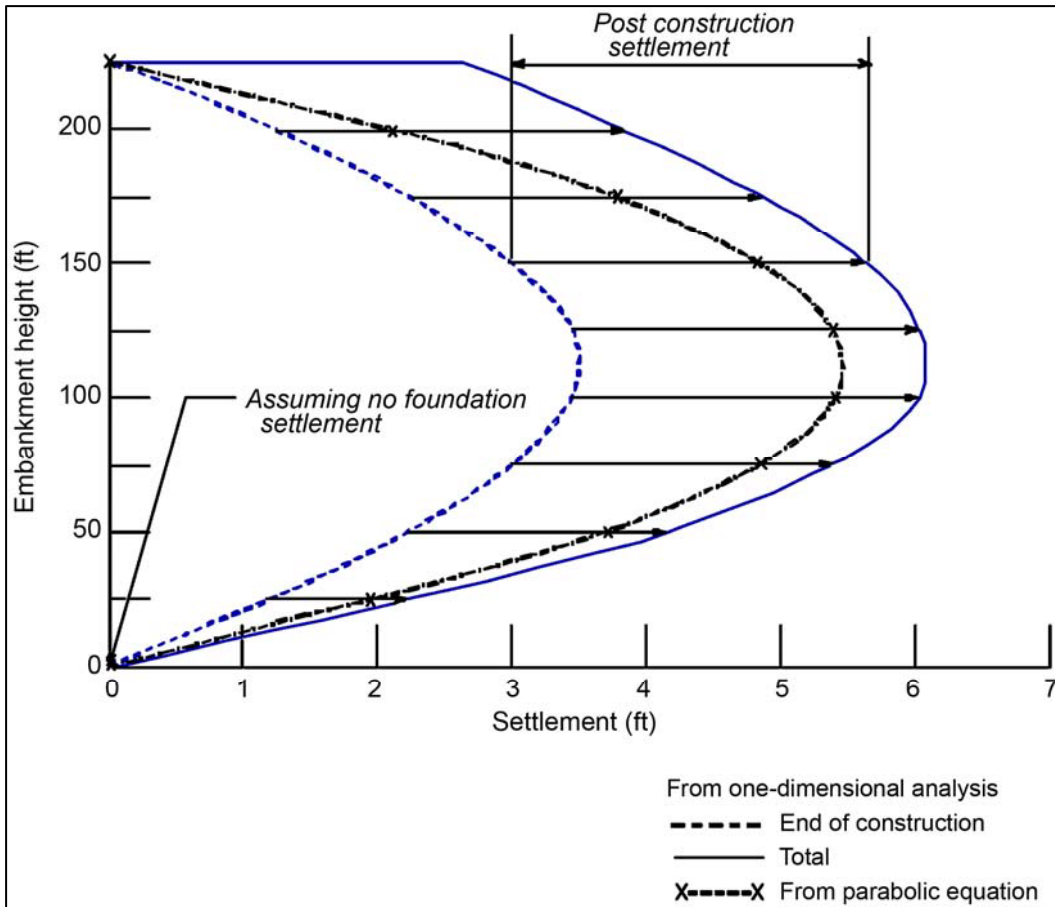

Figure A-5. Comparison of results of one-dimensional equation and parabolic settlement calculations

## **Appendix B**

# **Examples of Settlement Analyses Related to Real Dams**

- Part 1*    Analysis of Foundation Settlements at Ridgway Dam
- Part 2*    Settlement Evaluation, Horsetooth Reservoir Dams Modification
- Part 3*    Ridges Basin Dam – Embankment Settlement and Construction  
              Pore Pressures

Each of these documents is self explanatory, and no additional comments are considered necessary.



## **Appendix B**

*Part 1*    Analysis of Foundation Settlements at Ridgway Dam by  
Ashok K. Chugh and Luther W. Davidson

This article was published in the Canadian Geotechnical Journal, Volume 25,  
pp. 716-725, 1988, Natural Resource Council



Ridgway Dam (near Montrose, Colorado).

## Analysis of foundation settlements at Ridgway Dam

ASHOK K. CHUGH AND LUTHER W. DAVIDSON

United States Department of the Interior, Bureau of Reclamation, Engineering and Research Center, Denver, CO 80225, U.S.A.

Received April 7, 1988

Accepted April 19, 1988

The foundation material at the Ridgway Dam site is broadly classified as mudstone. The observed foundation settlements along the invert of the river outlet-works conduit at Ridgway Dam are on the order of 0.3 m. Numerical analyses were performed to estimate the deformation properties for a foundation material that under the existing embankment loads would deflect in a manner similar to the settlements surveyed along the invert of the outlet-works conduit. The foundation deformation properties determined from these analyses are compared with those obtained through the laboratory testing of the site-specific foundation materials and the published data. The results of the analyses, the field instrumentation data, the site geology, and the laboratory data provided an input to the decision-making process for the rehabilitation of the river outlet-works conduit.

*Key words:* foundations, settlements, embankment dams, mudstones, analysis.

Le matériau de fondation sur le site du barrage Ridgway est généralement classifié comme un mudstone. Les tassements observés de la fondation du radier de la conduite de fuite dans la rivière sont de l'ordre de 0,3 m. Les analyses numériques ont été réalisées dans le but d'estimer les propriétés de déformation pour le matériau de fondation qui, sous les charges du remblai existant, va subir une déflexion similaire aux tassements qui ont été relevés le long du radier de la conduite de fuite. Les propriétés de déformation de la fondation déterminées au moyen de ces analyses ont été comparées à celles qui ont été obtenues par des essais de laboratoire sur le matériau de fondation spécifique à ce site, et les données sont publiées. Les résultats des analyses, les données de l'instrumentation sur le chantier, la géologie du site, et les données de laboratoire ont fourni un ensemble d'éléments utilisés dans le processus de décision quand à la méthode de réhabilitation de la conduite de décharge dans la rivière.

*Mots clés :* fondations, tassements, barrages en terre, mudstones, analyse.

[Traduit par la revue]

Can. Geotech. J. 25, 716-725 (1988)

### Introduction

Ridgway Dam is a zoned earthfill embankment across the Uncompahgre River in Ouray County near Montrose, Colorado, U.S.A. The embankment dam has a maximum height of 102 m<sup>1</sup> above the stream bed and a crest length of approximately 750 m. Figure 1 shows the location map and general layout of the Ridgway Dam and its appurtenant structures. The dam was completed in 1987.

The river outlet-works conduit is located on a relatively flat foundation and has about 65.5 m of embankment fill above it under the crest of the dam (see Fig. 1). Figure 2 shows the profile and some cross-sectional details along the outlet-works conduit.

In January 1986, cracking of the river outlet-works conduit was observed and a survey of the conduit invert was made. This survey indicated that settlement had occurred. The maximum settlement was 0.23 m, near station 11 + 11. At the time of this survey, embankment construction near the river outlet-works conduit had been completed to elevation 2078.7 m. Embankment construction was completed in September 1986 when the crest elevation of 2098.9 m was reached. A second survey was completed in October 1986. It indicated that the maximum settlement was 0.28 m, near station 11 + 24. Another survey in early December 1986 showed that the total settlement near station 11 + 24 had increased to 0.29 m. Two

additional surveys later in December 1986 indicated no additional settlement. Figure 2 shows the surveyed settlements along the invert of the conduit. From March to September 1987 there had not occurred additional settlements along the conduit length due to reservoir loads.

There are several methods and practices available for use in predicting settlements of structures (Hamdy 1986). Their use in engineering practice is a matter of individual or organizational preference and past experience.

The objectives of this paper are:

- (1) to present the rationale for selecting the particular analysis procedures for estimating the deformation properties of a foundation material that under the existing embankment loads would deflect in a manner similar to the settlements surveyed along the invert of the river outlet-works conduit;
- (2) to present the results of numerical analyses;
- (3) to present a comparison of numerical analysis results with the laboratory data on site-specific foundation materials and the published data from the literature.

It should be kept in mind that the cumulative settlement data and the embankment loading causing the settlements were the only reliable site-specific data available for analysis purposes at the time of this study. The results of laboratory investigative studies, performed in conjunction with the foundation settlements, became available toward the end of the analytical studies. The preconstruction laboratory data could not be completely relied upon because the observed settlements were considerably greater than anticipated. The preconstruction geologic investigations and foundation exploration data were available and used only for the benefit of the problem definition. The problem as posed for analysis is incomplete. The

<sup>1</sup>Imperial units were used on this project. The data and analyses reported in this paper were converted, wherever practicable, to metric units and conveniently rounded. The numeric information contained in this paper should, therefore, be interpreted keeping in mind this change of units.



TABLE 1. Preconstruction rock mechanics laboratory unconfined compression strength test results on mudstone samples (Babcock 1983)

Sample depth (m)	Sample length/diameter	Unconfined compressive strength, $q_u$ (MPa)	Static secant modulus of elasticity, $E_s$ , at 40–60% of ultimate strength (MPa)	Calculated undrained shear strength, $S_u = \frac{1}{2} q_u$ (MPa)	$E_s/S_u$ (approx.)
17.5	1.60	0.5	34	0.25	141
22.3	2.06	3.7	207	1.8	113
22.8*	2.02	4.3	414	2.2	192
22.9	2.01	2.1	207	1.1	193
25.5	1.81	18.5	1 380	9.2	149
140.3	1.97	32.8	6 895	16.4	421
142.6	2.15	44.6	96 525	22.3	4328

\*Specimen dried during preparation.

back-calculated values of the operating deformation properties for the foundation material shall depend on the assumptions made in defining the problem. Therefore, the reasonableness of back-calculated values of deformation properties of the foundation material must be evaluated in view of the site-specific laboratory data, and other data available in the literature. Even though this comparison is after-the-event, it may serve as a useful learning exercise for future use in geotechnical engineering practice.

Though it may appear to be an unusual set of conditions for an engineering problem, it did happen in practice and requires a solution. Thus, the approach to the problem at hand and the methods of analysis adopted may be of equal significance.

A brief description of the site geology and representative site-specific laboratory data is presented first, then the main objectives of the paper. Additional information on these items can be obtained from the authors on request.

### Site geology

The dam and the river outlet-works conduit are founded on the Morrison Formation of Jurassic age. The Morrison Formation is about 213 m thick near the damsite and is divided into the upper Brushy Basin member and the lower Salt Wash member. The Brushy Basin member is exposed in the damsite area and is the foundation for the river outlet-works conduit. This formation consists mainly of shale and mudstone units with random, generally thin- to medium-bedded sandstone and siltstone layers. The Salt Wash member was not encountered during the dam construction and is thought to occur at more than 30 m below the conduit. The Salt Wash member contains massive sandstone beds interstratified with layers of mudstone.

Five shallow drill holes with depths 2.4–15 m below the conduit were completed in conjunction with this investigation. The geologic logs and visual inspection of the drilled core show high variability in the thickness and integrity of the mudstone layers. Based on these logs, it is estimated that approximately 26–33% of the foundation material is very soft to medium mudstone ( $q_u = 0.2$ – $0.7$  MPa).

Applying the estimate of 30% of the foundation material to be of soft to medium mudstone to a depth of 30 m below the conduit, one would infer a thickness of compressible foundation material of ~9 m.

### Laboratory data

The preconstruction rock mechanics laboratory tests on mudstones from the Ridgway Dam site were performed on core samples from the dam's drainage and grouting tunnel.

These test results are shown in Table 1 (Babcock 1983.)

To study the problems associated with the conduit settlement, additional soil mechanics laboratory testing was performed on the very soft to medium mudstone samples taken from under the river outlet-works conduit. Eleven NX size and 15.25 cm diameter waxed core samples and three 15.25 cm diameter samples protected in split polyvinyl chloride pipe were obtained for laboratory investigations. All tests were performed in accordance with procedures described in the Earth Manual (1980). Some of these representative test results are shown in Tables 2 and 3 (Redlinger and Casias 1987).

### Rationale for analyses

The compressibility of a foundation material may be characterized in terms of

- (1) coefficient of subgrade reaction,  $K$ ;
- (2) Young's modulus of elasticity,  $E$ , and Poisson's ratio,  $\nu$ ;
- (3) recompression index,  $C_r$ , and (or) compression index,  $C_c$ , and initial void ratio,  $e_0$ .

Associated with each of the above characterizations of material is a method of settlement calculation. Obviously, one needs to make additional assumptions with regard to material behaviour, i.e., linear or nonlinear for characterizations (1) and (2), normally consolidated or overconsolidated for (3); thickness of foundation undergoing compression for (2) and (3); boundary conditions for (1), (2), and (3), etc. For purposes of this paper, only linear, homogeneous, and isotropic properties for  $K$ ,  $E$ ,  $\nu$ , and a uniform value for the slope of the  $e - \log p$  curve for  $C_c$  are considered.

The motivation for the choice of analysis methods came, in general, from the following considerations:

- (1) The embankment load and the foundation settlement data have provided a pseudo-plate bearing test of the prototype foundation and one should be able to calculate the coefficient of subgrade reaction,  $K$ , which is an average representation of the load–deformation behaviour of the entire foundation under the dam. The magnitude of  $K$  shall indicate whether the foundation behaviour is one of a soil-like material or a rock-like material.
- (2) If the foundation deformations occurred over a short time, the foundation response to embankment load should be essentially elastic, and one needs to know  $E$  and  $\nu$ .
- (3) If the foundation deformations occurred over some time, the foundation settlement under embankment load should be due to consolidation of the foundation materials, and one needs to know  $C_r$ ,  $C_c$ ,  $e_0$ , etc.

The number and significance of assumptions required for



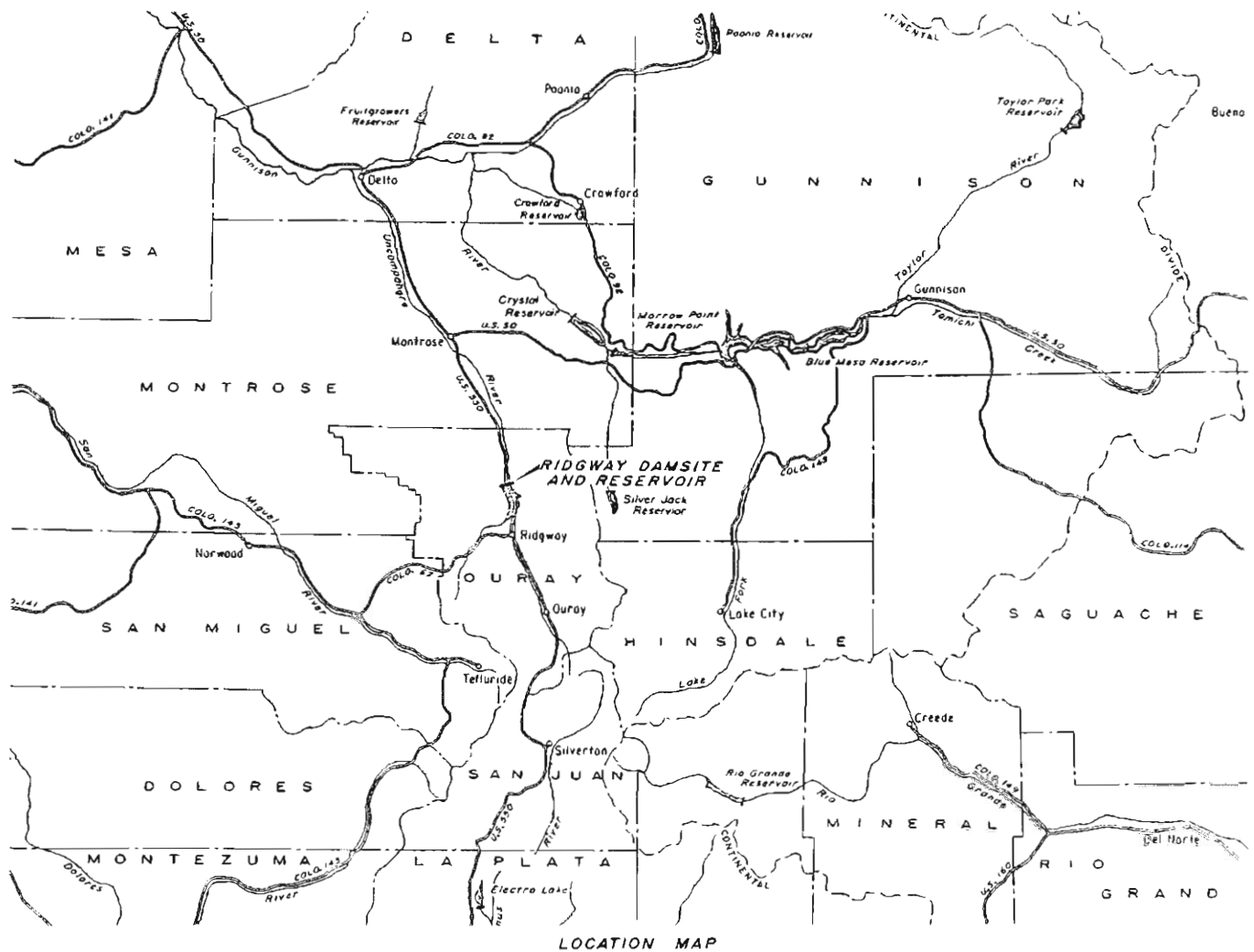

FIG. 1. Location map and general layout of the Ridgway Dam and appurtenant structures.

making the analyses depended on the analysis procedure adopted. These are described in the following section (Chugh 1987).

### Analyses and results

#### 1. Coefficient of subgrade reaction

The analytical model for this calculation is shown in Fig. 3. In this approach the surveyed settlement data are used to calculate the total vertical reaction assuming a uniform coefficient of subgrade reaction,  $K$ , and seeking static equilibrium of forces in the vertical direction (see Fig. 3). The main assumptions of this procedure are

- no interelement shear;
- a uniform and linear load—displacement response of the foundation material;
- only vertical displacements;
- an incompressible foundation underlies the compressible zone.

The calculated value of  $K$  is about 6.11 MPa/m of settlement. This is indicative of a soil-like behaviour of the foundation material. Obviously, this calculation procedure does not require a prior knowledge of the thickness of the foundation material within which the settlement occurs. The results of this calculation provided a convenient measure of the deformation

characteristic of the foundation material based only on the surveyed settlement data and the weight of the dam.

#### 2. One-dimensional elastic analysis

This simple calculation procedure was used to estimate magnitude (high or low) of modulus of elasticity of the foundation material using the observed settlement data. The analytical model for this calculation is shown in Fig. 4. In the use of this approach, the thickness of compressible foundation zone at any point was assumed to be a constant fraction of the embankment height above it. A uniform modulus of elasticity value for the foundation material is calculated by seeking an equilibrium of forces in the vertical direction (see Fig. 4). The main assumptions of this procedure are the same as those for analysis 1 above.

The results of this analysis show that the modulus of elasticity,  $E$ , of the compressible foundation zone should be quite low for a reasonable depth of influence in the dam foundation.

#### 3. Two-dimensional elastic analysis

The analytical model for this calculation is shown in Fig. 5. This analysis is similar to analysis 2 described above except that a uniform depth of compressible foundation is assumed and interelement shear is allowed. The table in Fig. 5 shows the assumed elastic properties for the embankment materials.

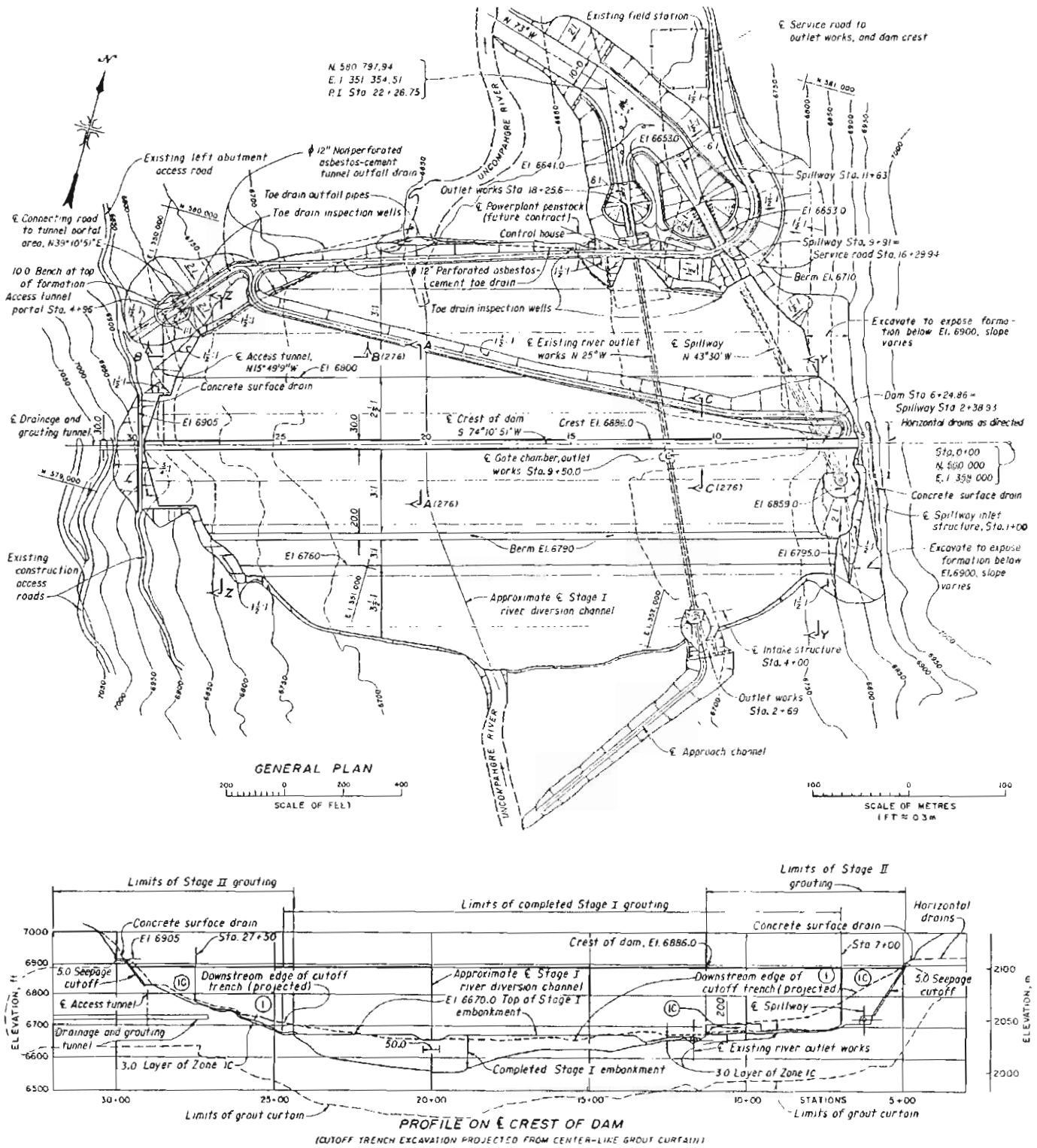

FIG. 1 (concluded)

By making three finite element analyses, using zero density and assumed elastic properties for the compressible foundation layer, a uniform modulus of elasticity of about  $\sim 4.86$  MPa/m thickness of compressible layer was estimated to yield the deflection curve that matches well the measured settlement data (see Fig. 5). However, the thickness of compressible foundation layer is needed to fix a value for  $E$ .

The results of analyses shown in Figs. 4 and 5 should be

interpreted for a reasonable thickness of the compressible layer, as the deformations are allowed to occur only in this layer.

4. One-dimensional consolidation settlement analysis

The analytical model for this calculation is shown in Fig. 6. This analysis is for the possibility that all deformations observed are a result of consolidation in soft materials. The

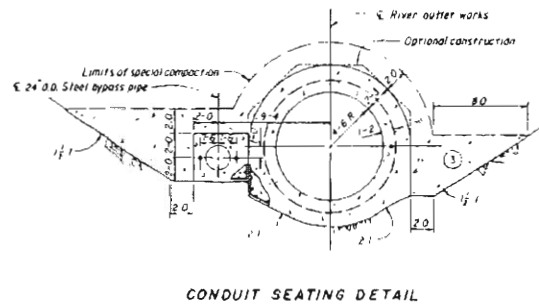
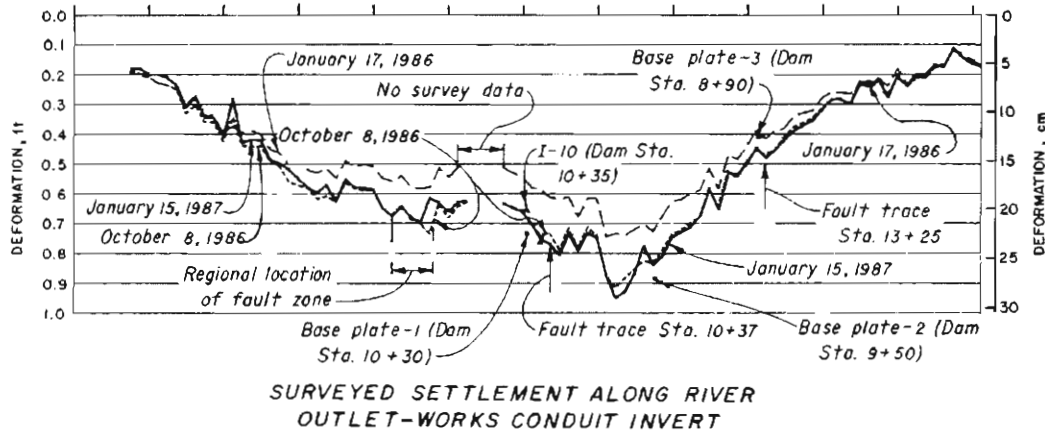
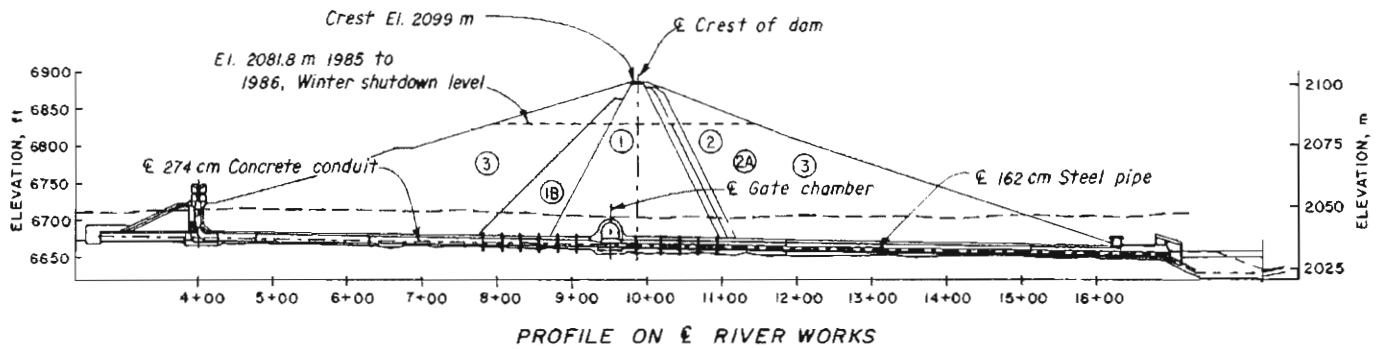

NOTE:  
1 in. = 25.4 mm

CONDUIT SEATING DETAIL

Fig. 2. General layout of the river outlet-works conduit and observed settlements along the conduit invert. Embankment explanation for circled numbers: 1. Selected clay, silt, sand, gravel, and cobbles to 5 in. maximum size compacted by tamping roller to 6 in. layers. 1A. Processed coarse-grained materials compacted by vibratory rollers to 12 in. layers (stage I only). 1B. Selected clay, silt, sand, gravel, and cobbles to 12 in. maximum size compacted by pneumatic tired rollers to 12 in. layers. 1C. Selected clay, silt, sand, and gravel of higher plasticity to 3 in. maximum size compacted by tamping rollers to 6 in. layers. 2. Processed sand filter, compacted by vibratory rollers to 12 in. layers. 2A. Processed gravel drain, compacted by vibratory rollers to 12 in. layers. 3. Selected silt, sand, gravel, and cobbles to 12 in. maximum size compacted by vibratory rollers to 12 in. layers. 3A. Processed gravel and cobbles to 12 in. maximum size compacted by vibratory rollers to 12 in. layers.

main assumptions made in this calculation were  
—initial void ratio  $e_0 = 1.0$  for the compressible foundation material, which allowed a convenient scaling of calculation results for other values of  $e_0$ ;  
—compression index,  $C_c$ , is the same for all compressible foundation material;  
—change in vertical stress due to embankment load is given by the relation  $\Delta\sigma = \gamma_{emb} \times h_{cmb}$ ;

—an incompressible foundation underlies the compressible layer.

The settlement calculations were made at three different locations along the conduit using the standard formula shown in Fig. 6. The thickness of compressible layer was varied in increments of 3 m. Results of these calculations are shown in Fig. 6 for the three locations. The observed settlements at the corresponding locations are drawn in Fig. 6.

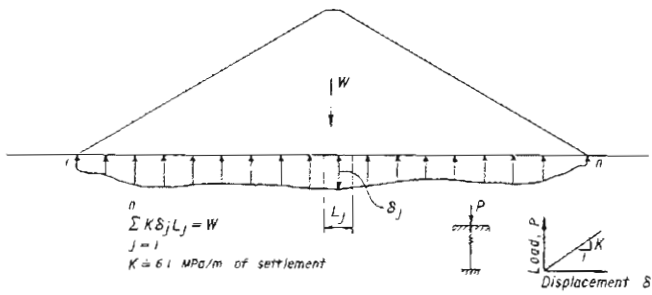

Fig. 3. Coefficient of subgrade reaction model and results.

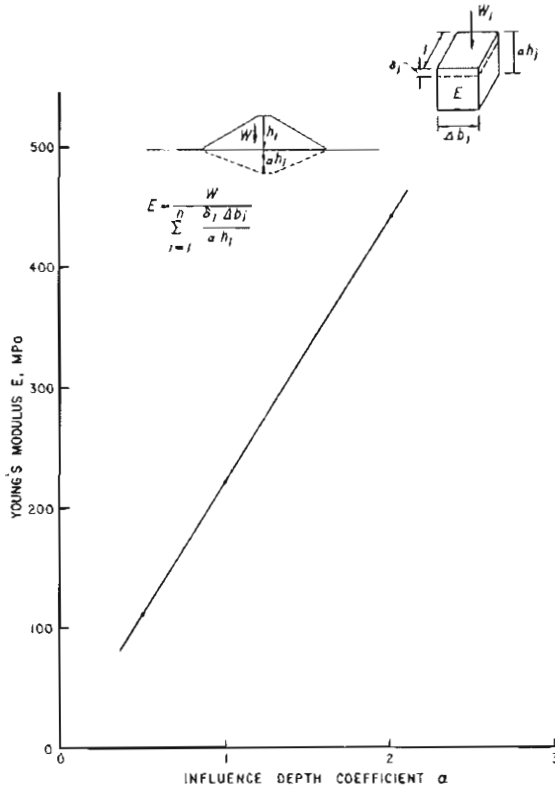

Fig. 4. One-dimensional elastic model and results.

Comparing the cumulative settlement data of November 1, 1986, with the calculated values, one can infer that  
 — $C_c$  should be between 0.05 and 0.15;  
 —compressible foundation thickness should be between 4.6 and 9.1 m for  $C_c = 0.05$ ; 1.2 and 2.4 m for  $C_c = 0.15$ .

**Interrelation between elastic properties and compression index**

The elastic material properties,  $E$  and  $\nu$ , and the compression index,  $C_c$ , are related through constrained modulus,  $D$ , by the following equations:

[1]  $D = \frac{E(1 - \nu)}{(1 + \nu)(1 - 2\nu)}$

[2]  $C_c = \frac{(1 + e_0)}{0.435D} \sigma_{va}$

TABLE 2. Postconstruction soil mechanics laboratory one-dimensional consolidation test results on mudstone samples (Redlinger and Casias 1987)

Drill hole location	Sample depth (m)	Liquid limit (%)	Plasticity index (%)	Initial void ratio $e_0$	Initial moisture content (%)	Compression index		Recompression index		Preconsolidation pressure (MPa)
						Natural moisture content	Wet	Natural moisture content	Wet	
Under the dam	2.1–2.4	46	20	0.51	19.3	0.09	0.02	0.02	0.02	0.62
Under the dam	4.3–4.7	42	19	0.32	11.5	0.03	0.05	0.05	0.04	0.24
Downstream of the dam	1.7–2.0	34	14	0.53	17.9	0.06	0.05	0.01	0.02	0.52
Downstream of the dam	7.5–7.8	27	8	0.28	10.5	0.09	0.05	0.02	0.02	0.28
Downstream of the dam	9.4–9.6	35	14	0.39	13.8	0.09	0.06	0.02	0.02	0.31
		26	10	0.35	14.0	0.15	0.10	0.06	0.10	0.69
		43	21	0.47	16.9	0.35	0.35	0.15	0.15	0.59

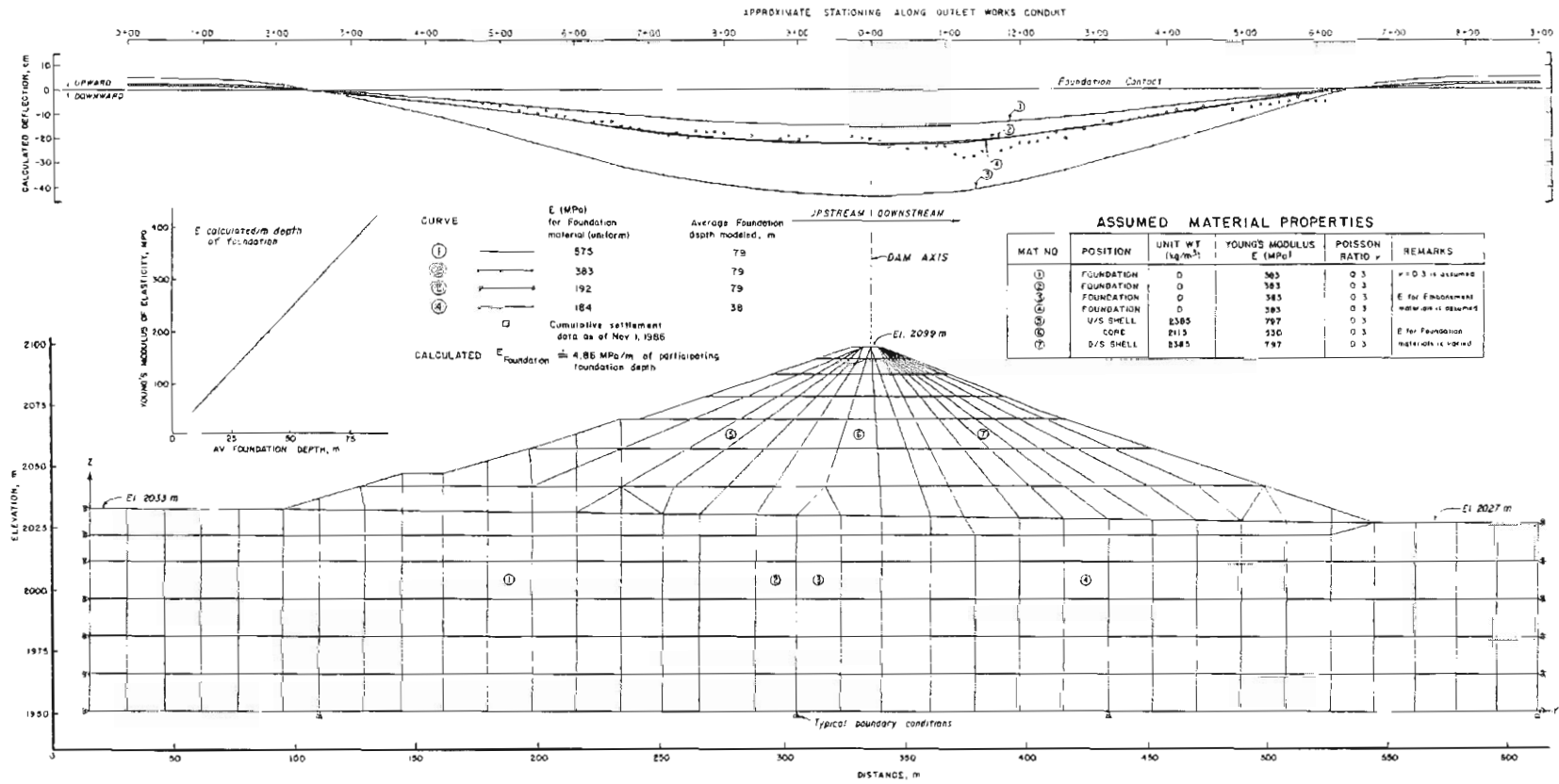

FIG. 5. Two-dimensional elastic model and results:

TABLE 3. Postconstruction soil mechanics laboratory unconfined compressive strength test results on very soft to medium mudstone samples (Redlinger and Casias 1987)

Sample depth (m)	Sample length/diameter	Unconfined compressive strength, $q_u$ (MPa)	Tangent modulus of elasticity, $E_s$ , at 40–60% of ultimate strength (MPa)	Calculated undrained shear strength, $S_u = \frac{1}{2} q_u$ (MPa)	$E_s/S_u$ (approx.)
2.1–2.4	1.95	0.65	21	0.33	64
4.3–4.7	1.89	0.20	4	0.10	35
9.4–9.6	2.22	0.33	25	0.16	153

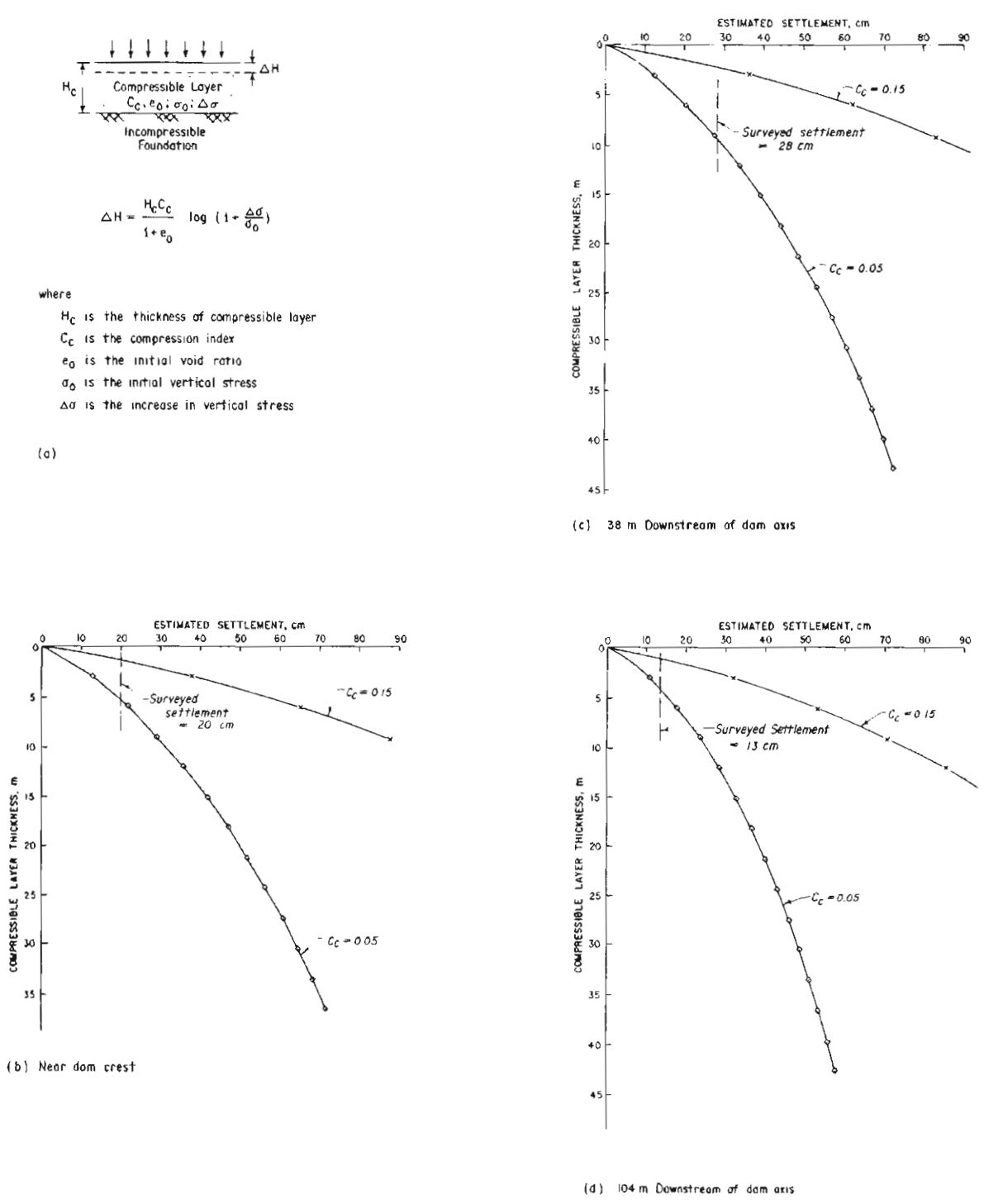

FIG. 6. One-dimensional consolidation settlement model and results.

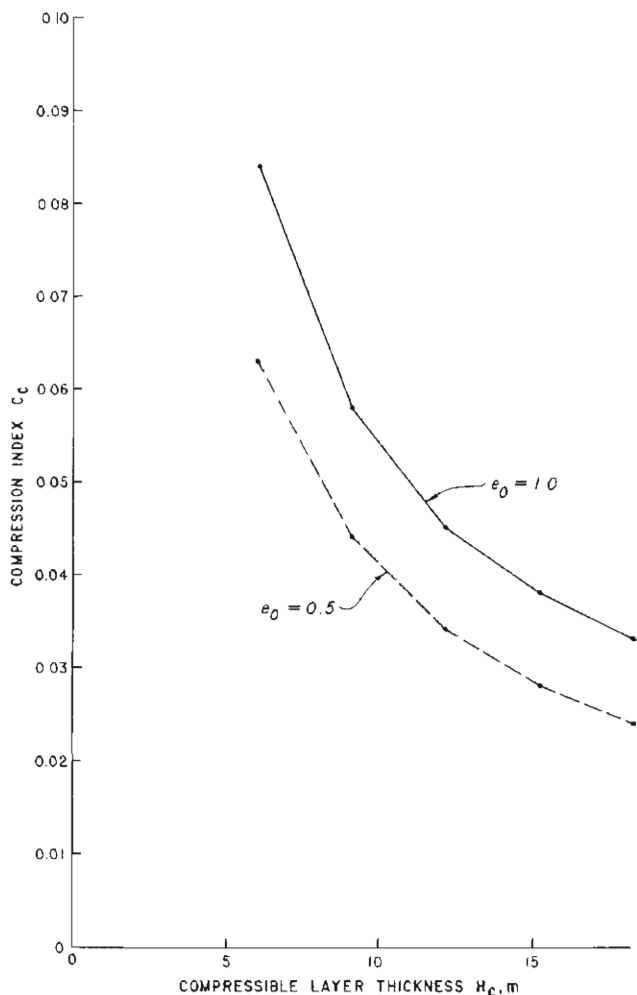

FIG. 7. Calculated interrelation between one-dimensional consolidation parameters, eq. [3].

where  $\sigma_{va}$  denotes the average of the initial and final vertical normal stress.

Using the results of two-dimensional elastic analysis, that is,  $E = 4.86H_c$  MPa and  $\nu = 0.3$ , in [1], one gets  $D = 6.54H_c$  MPa.  $H_c$  denotes the thickness of the compressible layer in metres. Expressing  $\sigma_{va} = 0.5(\gamma_{emb} \times h_{emb} + \gamma_{found} \times H_c)$  and substituting the expression for  $D$  in [2], one gets

$$[3] \quad C_c = \frac{(1 + e_0)(0.673 + 0.0098H_c)}{2.845H_c}$$

for the near dam crest location.

Figure 7 is a plot of [3] for  $C_c$  versus  $H_c$  for  $e_0 = 0.5$  and  $1.0$ . This provides a calculated relationship, using the results of two-dimensional elastic analysis, for the one-dimensional consolidation parameters  $C_c$ ,  $e_0$ , and  $H_c$ .

### Discussion and summary of results

The two-dimensional elastic analysis results indicate that  $E = 4.86$  MPa/m thickness of compressible layer gives a reasonable match between the computed deflection curve and the surveyed settlement along the conduit invert.

The interrelation between the elastic properties and compression index, using the results of the two-dimensional elastic model, gives possible combinations of  $C_c$ ,  $e_0$ , and  $H_c$  for equally reasonable results from the consolidation settlement

analysis. The results shown in Fig. 6 agree quite well with the interrelationship results shown in Fig. 7. Supplementing this information with the geologic logs, visual inspection of the drilled cores, and the local geology, one can infer that there is about 9 m of compressible material in the foundation under the river outlet-works conduit. For calculation purposes, however, this 9 m of compressible material was lumped together and placed at the embankment–foundation contact.

Using  $H_c = 9$  m, one obtains  $E = 44$  MPa,  $\nu = 0.3$  from the two-dimensional elastic analysis; and  $e_0 = 0.5$ ,  $C_c = 0.044$  or  $e_0 = 1.0$ ,  $C_c = 0.058$  from the one-dimensional consolidation analysis as estimates for the deformation properties for a foundation material that, under the Ridgway embankment loading, would deform in a manner similar to that observed. The coefficient of subgrade reaction,  $K$ , is about 6.11 MPa/m of settlement.

### Comparison of results

The  $C_c$ ,  $e_0$  and  $E$ ,  $\nu$  values estimated by the back analyses of the observed settlements at the Ridgway Dam are consistent with the values obtained by mathematically interrelating the two characteristic properties of soils, that is, the constrained modulus,  $D$ , and the compression index,  $C_c$ .

The preconstruction rock mechanics laboratory data on mudstone samples and postconstruction soil mechanics laboratory data on soft to medium mudstone samples from the Morrison Formation at the damsite are shown in Tables 1–3. There were variations in the rock samples, even though they were generally classified as mudstones. The secant modulus values for mudstones, Table 1, at 40–60% of the ultimate strength, range between 34 and 96 500 MPa.

The tangent modulus, at 40–60% of the ultimate strength, from the soil mechanics laboratory data for soft to medium mudstones, Table 3, range between 4 and 25 MPa. Since the softer units in the foundation must be responsible for the observed settlements, the back-analysed value for  $E = 44$  MPa is in fair agreement with the laboratory data.

The computed value of compression index is in fair agreement with the laboratory one-dimensional consolidation test results shown in Table 2.

There is no published data on engineering properties of Morrison shales (Underwood 1967). Figure 8 is a plot of the uniaxial compression strength versus Young's modulus for typical rocks and clays (Legget and Karrow 1983). If one considers mudstones as a subcategory of shale, the laboratory data of  $E$ ,  $q_u$  fit the published data quite well, as shown in Fig. 8. However, the laboratory data on soft to medium mudstones do not fit the statistical relations for clays, such as  $C_c = 0.009(LL-10)$ ,  $S_u = (0.11 + 0.0037I_p)\bar{\sigma}_v$ , and  $E = 600S_u$  (Peck 1974).

### Actual conduit performance during reservoir filling

The river outlet-works conduit is instrumented with remote-reading strain gauges along its upstream length, and with settlement points and telltale gauges along the downstream length. The upstream and downstream lengths are referenced from the gate chamber (see Fig. 2). The reservoir filling commenced in March 1987 and rose from elevation 2060 m to about elevation 2083 m by July 1987. The reservoir was drawn down to elevation 2073 m in August and September 1987 to facilitate construction of upstream recreation facilities. From March to September 1987, there did not occur any discernible

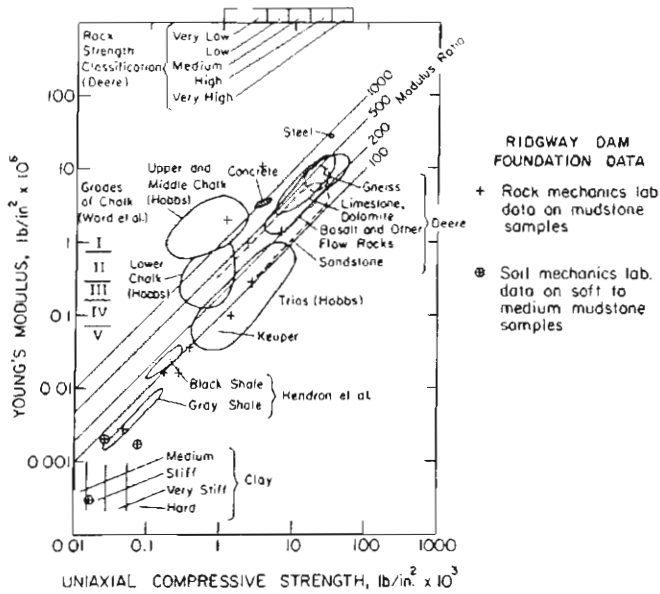

FIG. 8. Relation between the compressive strengths and Young's moduli for typical rocks and clays (Legget and Karrow 1983). (1 lb/in<sup>2</sup> = 6.89 kPa.)

deformation along the conduit length due to reservoir loads. During the 1988 filling season, the reservoir rose to elevation 2086 m and again there has been no further settlement of the conduit.

**Conclusions**

The deformation properties for the compressible foundation material under the river outlet-works conduit at Ridgway Dam as calculated by the back analyses fit the site-specific laboratory test data and the published data quite well. Even though these comparisons are after-the-event, they provide a useful learning exercise for possible future use in geotechnical engineering practice. The analysis procedures selected for the problem were intended to be simple. While the analysis results

by themselves provided a reasonable indication of possible values for the deformation properties of the compressible foundation material, a knowledge of the site geology and visual inspection of the drilled core were required to assign the numerical values to the various parameters. The values thus determined yield deflections that match well the measured settlement pattern.

**Acknowledgements**

A sincere appreciation is expressed to Harold Blair, Terry Casias, Robert Hart, Chuck Redlinger, and John Roberts for their discussions and comments during the study reported in the paper. Thanks are also due Dr. A. D. M. Penman and Professors W. Lee Schroeder and B. Amadei for their reviewing the initial draft of this paper and making useful suggestions. The reviewers for the journal made suggestions to improve the paper and the authors sincerely appreciate their helpfulness.

BABCOCK, J. T. 1983. Rock mechanics laboratory test results—Ridgway Dam drainage and grouting tunnel and access tunnel. Internal report, United States Bureau of Reclamation, Denver, CO.  
 CHUGH, A. K. 1987. Estimations for observed settlements under outlet-works conduit. Internal Report No. RD-230-3, United States Bureau of Reclamation, Denver, CO.  
 EARTH MANUAL. 1980. United States Department of the Interior, Bureau of Reclamation, Washington, DC.  
 HAMDY, K. 1986. Survey of settlement prediction methods and practices. Oregon State University, Corvallis, OR.  
 LEGGET, R. F., and KARROW, P. F. 1983. Handbook of geology in civil engineering. McGraw-Hill, New York, NY, p. 7-3.  
 PECK, R. B. 1974. The selection of soil parameters for the design of Foundations. Second Nabor Carrillo Lecture, Mexican Society for Soil Mechanics.  
 REDLINGER, C. G., and CASIAS, T. J. 1987. Results of physical properties and one-dimensional consolidation tests for the river outlet-works conduit at Ridgway Dam. International Report, United States Bureau of Reclamation, Denver, CO.  
 UNDERWOOD, L. B. 1967. Classification and identification of shales. ASCE Journal of the Soil Mechanics and Foundations Division, 93(SM6): 97-116.



## **Appendix B**

*Part 2* Settlement Evaluation, Horsetooth Reservoir Dams Modification

(Technical Memorandum No. HT 230-3)



Horsetooth Reservoir Dam (near Fort Collins, Colorado).

Technical Memorandum No. HT-230-3

Settlement Evaluation

Horsetooth Reservoir Dam Modification  
Colorado-Big Thompson Project, Colorado

Bureau of Reclamation  
Engineering and Research Center  
Embankment Dams Branch

Scope: This Technical Memorandum contains an evaluation of the probable cause of the settlement of the Horsetooth Reservoir Dams. The camber required to allow for future settlement of the dams is estimated.



## CONTENTS

<u>Section</u>	<u>Page</u>
I. Introduction . . . . .	1
II. Embankment design and construction . . . . .	2
III. Performance . . . . .	8
IV. Laboratory testing . . . . .	12
V. Discussions . . . . .	13
VI. Camber requirements . . . . .	17
VII. Conclusions . . . . .	18



## I. Introduction

Settlement point measurement surveys on the Horsetooth Reservoir Dams indicate a maximum settlement of approximately 4 feet at a point 42.5 feet upstream of station 8+99.8 on Dixon Canyon Dam. Settlements of lesser magnitude have been measured at each of the other dams. The most settlement occurred near the maximum section of the dams with smaller amounts near the abutments. The settlement measured to date represent approximately 2 percent of the height of the dam, which is not unreasonable for the zone 1 materials used to construct these structures and the placement conditions. This magnitude of settlement would not be unreasonable for the total settlement from the beginning of construction. It is unusual to have this amount of settlement since completion of construction. The rate of settlement, although decreasing with time, has not decreased as would be expected. The settlement is still occurring along the normal consolidation portion of the settlement versus log time curve and had not achieved secondary compression after almost 35 years of operation, as can be seen on figure 1 for Spring Canyon Dam. These plots are representative of plots for other settlement measurement points.

The apparent reason for the continued settlement is immediate settlement of zone 1 materials as reservoir water permeates through the embankment. This immediate settlement appears to be the result of wetting up of zone 1 materials placed too dry of optimum water content. Zone 1 material at Spring Canyon Dam was placed with an average moisture content of 2.9 percent dry of optimum moisture. Construction records indicate that some zone 1 materials were placed as much as 6 percent dry of optimum moisture.

In clays, the water content has an important influence, as it controls the ease with which particle groups can be rearranged under the compaction effort used (14). For compaction dry of optimum water content, the tamper does not penetrate the soil. There is a general alignment of particles or particle groups in horizontal planes. A flocculated structure of particles with edge to edge or edge to face association and random arrangement results. This structure is stiff and brittle, and when saturated, immediate settlement results. At the same compactive effort, with increasing water content, the soil structure becomes increasingly orientated or dispersed. For soils compacted wet of optimum water content, if the compactive effort is high enough, the tamper penetrates the soil surface as a result of a bearing capacity failure. This leads to an alignment of particles along the failure surface. Near optimum water content, for the same compactive effort, a denser arrangement of particles is achieved due to the ease of penetration of the tamper and immediate settlements due to saturation are reduced in magnitude.

In summary, clays compacted too dry of optimum moisture content are more sensitive to changes in water content than those compacted near optimum water content. Had all the material been placed at a moisture content less than 2 percent dry of optimum moisture, a major portion of the settlement would have occurred during construction and in the first few

years of operation. Saturation is not required for this phenomenon to occur. The soil need only approach optimum moisture.

This Technical Memorandum assesses the reason for the settlements. The anticipated camber required to accommodate future settlement without loss of freeboard will be estimated from one-dimensional consolidation tests performed on samples from Spring Canyon Dam.

## II. Embankment Design and Constuction

### A. Embankment Description

The Horsetooth Reservoir Dams can be described as essentially homogeneous dams. Each of the embankments has a wide zone 1 core and zones of sand and gravel, and rockfill on the upstream and downstream slopes, which provide slope protection and stability for the zone 1 core. A plan view and maximum section for each of the dams are shown on figures 2 through 5. The height of the dams above bedrock, crest length, and crest width for each of the dams are shown in table 1.

Table 1

Dam	Height (ft)	Crest length (ft)	Crest width (ft)
Horsetooth	155	1,840	35
Soldier Canyon	226	1,438	40
Dixon Canyon	240	1,265	40
Spring Canyon	220	1,120	40

The specifications describe zone 1 material as a mixture of clay, sand, and gravel obtained from required excavation and designated borrow pits. The material was compacted to 6-inch lifts by 12 passes of a tamping roller. The moisture content was specified to be the optimum practicable moisture content required for compaction purposes as determined by the contracting officer.

All the dams have rockfill zones (zone 4) located on the upstream slope. Dixon Canyon and Spring Canyon Dams also have a rockfill zone (zone 4) on the downstream slope. The specifications required that the rockfill be dumped and roughly leveled to produce and maintain a reasonably uniform gradation of materials as determined by the contracting officer. The material was placed in three feet lifts



with the larger fragments placed toward the outer slope and smaller fragments placed near the zone 1 core. There were no moisture content or compaction requirements for the zone 4 materials.

Horsetooth and Soldier Canyon Dams have downstream zones composed of sand, gravel, and cobbles placed in 12-inch layers. The zone 3 materials were compacted by sluicing methods. The material was saturated; then controlled passage of traffic was utilized for additional compaction.

#### B. Camber Design

Camber details were not included in the original specifications, completed in February 1946. Camber drawings were completed in February 1948, at which time nearly 50 percent of the earthfill had been placed in the embankments. Although the height above bedrock of Horsetooth Dam is 75 to 100 feet less than that of the other dams, each of the dams has the same design camber. The camber design provides for an additional 0.8 foot of material at the maximum section of the dam. The design camber is shown on figure 6. The design drawing provides an equation for computing camber and a table showing the elevations of the centerline of the dams with camber.

#### C. Consolidation Test Prior to Construction

A one-dimensional consolidation test was conducted in June 1945 on a representative sample of reservoir deposits prior to beginning construction in 1947. Reservoir deposits were used as the primary source for zone 1 materials. The testing showed consolidation of about 7.5 percent under maximum load, with very little additional consolidation upon saturation. The sample was loaded to the maximum anticipated load of 196 lb/in<sup>2</sup> and then saturated. Prior to testing, the sample was compacted to optimum dry density and optimum moisture. The material has an optimum moisture content of 16 percent and a maximum dry density of 110.5 lb/ft<sup>3</sup>.

#### D. Placement Information

A review of the construction records indicates that the zone 1 materials were placed an average of from 2 to 3 percent dry of optimum moisture content. The zone 1 materials in all the dams are classified as clay of low plasticity (CL) or silty clay (ML-CL) with 20 to 50 percent passing the No. 200 sieve. Table 2 shows the average material properties and standard deviations for the water content and dry density. Also included in table 2 are average and optimum penetration needle resistance test results. Penetration needle test results were used to control the placement moisture during the first construction season. Information in this table is from construction records obtained during construction from 1947 through 1949.

The penetration needle test is very sensitive to the moisture content, as the moisture content approaches optimum moisture the

Table 2. 1/

	Dam			
	Horsetooth	Soldier Canyon	Dixon Canyon	Spring Canyon
Average PI	11.6	12.8	12.8	14
Average LL, percent	26	27	27	28.8
Average optimum water content, percent	13.9	14.2	14.9	14.9
Average water content in fill, percent	11.7	11.6	12.1	12.0
Average percent dry of optimum water content	2.2	2.6	2.8	2.9
Standard deviation in water content, percent	<u>+1.7</u>	<u>+1.8</u>	<u>+1.7</u>	<u>+1.5</u>
Average dry density in fill (lb/ft <sup>3</sup> )	112.6	112.1	111.2	111.3
Average dry density proctor maximum (pcf)	114.9	114.1	112.9	112.6
Percent proctor density	98.0	98.2	98.5	98.8
Standard deviation in dry density, percent	<u>+4.0</u>	<u>+4.1</u>	<u>+3.7</u>	<u>+3.7</u>
Penetration needle, average for the zone 1 (lb/ft <sup>2</sup> )	1550	1470	1410	1330
Penetration needle, at optimum water content (lb/ft <sup>2</sup> )	680	570	540	570

1/ Information in this table is based on data presented in the final construction report on the Horsetooth Reservoir Dams.

resistance measured by the penetration needle decreases rapidly. Plots of penetration resistance versus water content have a steep curve. Small changes in water content have large effects on the penetration needle resistance. Therefore, the penetration needle is not a good way to control construction.

The data in table 2 indicate that 50 percent of the zone 1 material in the Horsetooth Reservoir Dams was placed from 2.2 to 6.2 percent dry of optimum water content. The average water content was 2.2 percent dry of optimum moisture. Statistically, using two standard deviations, the lower bound water content was 6.2 percent dry of optimum moisture. A normal distribution of the data was assumed.

#### E. Testing to Determine Limiting Moisture

In November 1947, testing to determine the limiting moisture for zone 1 materials placed at Horsetooth Reservoir was completed. The results of these tests are documented in Earth Materials Laboratory Report No. EM-152 entitled "Laboratory Test for Determination of the Placement Moisture Control Limits of Embankment Materials for the Horsetooth Reservoir Dams." The limiting moisture was to be used to control the placement moisture for zone 1 materials such that immediate settlement due to saturation, and instability due to high construction pore water pressures would be avoided.

Results of the tests from laboratory report No. EM-152 on an average zone 1 material are shown on figure 7. The average material had 17 percent clay, which is comparable with zone 1 material used in the construction of the embankments. The lower limit, defined by the heavy solid line, represents the lowest placement moisture content for the fill pressures shown if immediate settlement due to saturation was to be avoided. The primary concern at the time of this construction was high construction pore water pressures. It was thought that placement at the peak point of the moisture-density (compaction) curve was unsatisfactory for high earth dams. It was felt that the stability of high dams was greatly reduced by the development of pore pressures in soils placed at relatively high moisture conditions when the embankment consolidates as it is loaded during construction. Therefore, embankments constructed during this timeframe had zone 1 materials placed dry of optimum moisture.

Results of the tests from laboratory report No. EM-152 on an average zone 1 material are shown on figure 7. The average material had 17 percent clay, which is comparable with zone 1 material used in the construction of the embankments. The lower placement moisture limit was determined by using the one-dimensional consolidation test. The zone 1 materials were first tested to obtain a 33 blow compaction curve for the density moisture relationship. Test specimens were then prepared by compacting in the consolidometer of placement conditions given by the moisture-density curves for standard 33 blow compaction testing. Moisture contents of approximately 2, 4, and

6 percent less than optimum moisture and corresponding dry densities from the compaction curve for each material were selected for placement in the one-dimensional consolidation test. At each of these moisture contents, four specimens were consolidated under single increment loadings of 25, 100, 175, and 200 lb/in<sup>2</sup>. The consolidated density was obtained before and after saturation for each specimen. The full black lines were drawn through the densities attained, before saturation for the various placement conditions. The consolidated density versus placement moisture curves were then obtained for each load condition. The dotted line was drawn through the densities attained by these specimens after saturation without change in load. The point where these two curves intersect indicates the placement moisture content at which there will be no further consolidation of the material on saturation. By drawing a curve through the points of intersection for the different pressures, the lower limit for the material is established. The lower limit is represented by the heavy black line.

The one-dimensional consolidation test, which allows complete drainage, provides consolidation data for effective loads of 25, 100, 175, and 260 lb/in<sup>2</sup>. This information is used to estimate the total applied pressure necessary to produce the same consolidation, if the soil were sealed from drainage. From the total pressure and consolidation relation, the consolidations for total pressures of 25, 100, 175, and 250 are obtained under sealed conditions. These consolidation data are shown for the various pressures by the thin dashed lines on figure 7. Crossing these lines are heavier dashed lines which indicate the placement moisture at which can be expected various degrees of pore pressures for the fill pressures under consideration. The heavy dashed lines represent a percentage of the total applied load. The average material used in this test had an optimum moisture content of 13.4 percent. If the 20 percent pore pressure line is used as the upper limit, the range of moisture content satisfying the limiting criterion is approximately 12 to 14.5 percent. A criterion of 2 percent dry to 1 percent wet of optimum moisture would yield a range of moisture contents between 11.4 to 14.4 percent, which is approximately equal to the limits set for the material. However, the average placement moisture content was approximately 12 percent, which is approximately the lower limit moisture content to avoid immediate settlement due to saturation. Based on the field data shown in table 3 and the limiting moisture tests, as much as 50 percent of the zone 1 material had a moisture content drier than 12 percent and may be subject to immediate settlement due to saturation.

Placement of zone 1 materials started in the summer of 1947. When the limiting moisture tests were completed in November 1947, approximately 25 percent of earthfill had been placed. While waiting on the results of the limiting moisture tests, the construction office used the penetration needle test to control the placement moisture of the zone 1 materials. In a memorandum to the Project Construction Engineer dated March 7, 1947, the Chief Design Engineer

stated that the impervious embankment materials should be placed to attain penetration resistance needle readings between 1,500 to 2,000 lb/in<sup>2</sup>. Placing the material at these needle penetration resistance readings results in placement moisture contents of approximately 12 to 10 percent, respectively. As shown in table 2, the average needle penetration resistance for the fill was approximately 1,500 lb/in<sup>2</sup>. This average needle penetration resistance corresponds to a moisture content of 12 percent, which is approximately the average placement moisture for the embankments.

#### F. Foundation Conditions

Horsetooth Reservoir is situated within an area of sedimentary rocks. The beds dip a little north of east at angles of 18° to 40°. The rock units in the vicinity comprise an alternating sequence of hard layers of sandstone and softer layers of shale and sandy shale. The valley in which Horsetooth Reservoir lies is the result of erosion of the softer shales of the Lykins and Morrison Formations. The upturned ridge forming the eastern reservoir rim is the hard sandstone of the Dakota Group, while the western rim is formed by sandstone of the Lyons Formation. A more detailed description of the geology can be found in references 11 and 12. As shown on figures 2 through 5, a cutoff was excavated in overburden material to bedrock.

Horsetooth Dam extends from the Morrison Shale Formation on the right abutment, across the Sundance Sandstone Formation and the Lykins Shales, to the Lyons Sandstone Formation on the left abutment. Overburden on the slopes of the abutment consisted of a thin mantle of soil ranging in depth from 0 to 5 feet. The cutoff trench had a depth of 15 to 35 feet in the valley.

The foundation of Soldier Canyon Dam consists of the Dakota Sandstone Formation on the abutment slopes and the Morrison Shale Formation in the valley portion of the damsite. The overburden above the stream-bed of the canyon was a thin mantle of topsoil and approximately 5 feet of disintegrated and fractured shale. The overburden in the cutoff zone across the streambed was approximately 30 feet thick, consisting of a flood deposited mixture of boulders, gravel, and soil.

The foundation of Dixon Canyon Dam is composed of Morrison Shale Formation across the creek bed and Dakota Sandstone Formation on the abutments. Excavation to bedrock was required only in the cutoff trench for a width of 180 feet. However, due to unsuitable material, the width of the cutoff trench was extended approximately 100 feet upstream and 300 feet downstream of the edge of the cutoff trench.

The foundation of Spring Canyon Dam is composed of Morrison Shale across the valley bottom and Dakota Sandstone Formation on the abutments. Excavation to bedrock was required only in the cutoff trench for a width of 180 feet at the maximum section. The overburden consisted of approximately 7 feet of sand, gravel, and boulders overlying Morrison Shale in the valley section.

### III. Performance

#### A. Surface Cracks on Crest of Dixon Canyon Dam

In August 1952, longitudinal cracks were observed on the crest of Dixon Canyon Dam. The cracks were approximately 1-1/2 inches wide and 3 feet deep. The cracks appeared to coincide with the contacts of zone 1 and zone 1A on the upstream side of the crest and zone 1 and zone 2 on the downstream side of the crest. The cracks were attributed to settlement of the rockfill. Since the rockfill was placed without vibratory compaction and moisture to aid compaction, settlement of the rockfill and zone 1 will likely occur due to saturation of the rockfill slopes from first filling.

#### B. Settlement

Maximum settlements occur near the maximum sections of each of the dams. This condition generally reflects the compressibility of the embankment and/or foundation material. The foundation and/or embankment compress more at the maximum section due to the greater height of embankment. The settlement is less toward the abutments due to lesser fill heights. The foundation at Horsetooth Reservoir is rock and, therefore, not subject to significant compression on loading. Settlement is believed to be the result of embankment compression. Surveys of the crest and settlement measurement points on each of the dams were accomplished in December 1983 and January 1984. Table 3 shows the maximum settlement measured at the centerline of the dam and the maximum settlement measured at a settlement measurement point for each structure. Table 3 also shows the location of these settlements. The settlement measurement points are referenced to the axis of the dams, which is located 15 feet upstream of the centerline of Soldier Canyon, Dixon Canyon, and Spring Canyon Dams, and 12.5 feet upstream of the centerline of Horsetooth Dam. The settlement patterns are disk shaped. No anomalous areas were observed.

Table 3

Dam	Maximum settlement at center-line (ft)	Location station	Maximum settlement measured at a measurement point (ft)	Location of the settlement measurement point with maximum settlement
Horsetooth	1.5	10+00	2.2	Sta. 10+00, 30 ft downstream
Soldier Canyon	1.1	10+00	1.85	Sta. 11+13, 42.5 ft upstream
Dixon Canyon	3.5	10+00	4.05	Sta. 8+99.8, 42.5 ft upstream
Spring Canyon	2.8	5+00	2.95	Sta. 5+00, 42.5 ft upstream

Since Dixon Canyon and Spring Canyon Dams have experienced the most settlement, the majority of the discussions and analysis will concentrate on these structures. The settlement contours for Dixon Canyon and Spring Canyon Dams are shown on figures 8 and 9, respectively. The settlement patterns are not unusual and show maximum settlement occurring near the maximum section with lesser settlement on the abutments as the height of the embankment decreases.

Figures 10 through 13 are settlement-log time plots for Dixon Canyon and Spring Canyon Dams. Settlement measurement points at 42.5 feet upstream and 40 or 42.5 feet downstream of the dam axis are plotted. Based on the slope of the curves, the plots indicate that settlement is occurring along the primary consolidation portion of the consolidation curve. Although approximately 35 years have elapsed since the completion of construction, settlement has not entered the secondary compression phase. The data plotted for the last increment of settlement indicate a trend toward entering secondary compression, especially the settlement measurement point located 42.5 feet upstream of the dam axis on Spring Canyon Dam. As would be expected, the plots show that the maximum settlement occurs near the maximum section of the dam with smaller settlement occurring near the abutments, confirming the relationship of settlement to height of zone 1. Settlement measurement points such as station 3+00 and station 8+93.9 on figure 12 for Spring Canyon Dam appear to be experiencing secondary compression.

The plots of settlement versus time on a linear time scale also indicate that the rate of settlement is decreasing with time. As shown on figures 14 and 15 for Dixon Canyon and Spring Canyon Dams, respectively, the slope of the line becomes flatter with time. Rates of settlement throughout the period of operation are shown on figure 16 for Spring Canyon Dam at station 6+00. The high rates of settlement shown during the early period of operation are a reflection of initial filling.

During the first 10 to 15 years of operation, the upstream settlement measurement points had higher rates of settlement than the downstream settlement measurement points. Only settlement measurement points near the crest are analyzed. The trend reversed in approximately 1966; the downstream settlement measurement points had a higher rate of settlement than the upstream settlement measurement points. Figure 16 also shows a continuing trend toward decreasing rates of settlement.

The location of the rows of settlement measurement points near the crest of the embankments is shown in table 4. With the exception of Horsetooth Dam, the axis of the dams is located 15 feet upstream of the centerline of the dam. The axis of the dam in Horsetooth is located 12.5 feet upstream of the centerline.

Table 4. - Location of settlement measurement points

Dam	Upstream row		Downstream row	
	Distance from axis (ft)	Distance from centerline (ft)	Distance from axis (ft)	Distance from centerline (ft)
Horsetooth	50	62.5	30	18.5
Soldier Canyon	42.5	57.5	35	20
Dixon Canyon	42.5	57.5	42.5	27.5
Spring Canyon	42.5	57.5	40	25

The difference in settlement between upstream and downstream settlement measurement points (42.5 ft upstream and 42.5 ft downstream of dam axis) located near the crest of Dixon Canyon and Spring Canyon Dams are shown on figures 14 and 15. The plot shows that more settlement occurred at the upstream settlement measurement point until approximately 1960. The settlement of the upstream settlement measurement point occurred during first filling and may result from saturation of the rockfill and zone 1 materials. From



1960 through approximately 1970, the difference in settlement was relatively constant. In approximately 1970, the difference in settlement decreased, which indicates that the downstream settlement measurement point was experiencing more settlement than the upstream measurement point. The recent trend toward larger downstream settlements may be the result of immediate settlement due to saturation of zone 1 material as reservoir water continues to permeate further downstream.

The distance between upstream and downstream settlement measurement point rows near the crest varies from 77.5 to 85 feet. Although the distance is not great, the comparison of these rows are the most representative of the behavior of the structures. The upstream row is located in a normally saturated area and will reflect changes due to movement of the phreatic line first. The downstream row is located where the steady-state phreatic line takes longer to develop and, therefore, the effect of movement of the phreatic surface will be later. Both rows are in a location where the depth of the zone 1 beneath them is approximately the same and the thickness is also more than other settlement measurement points further down the slope. Settlement measurement points further down the slope will experience less settlement because of the difference in vertical stress and the thickness of the saturated zone 1 is also less.

The ratio of the settlement to the height of the zone 1 at each settlement measurement point was computed for Dixon Canyon and Spring Canyon Dams. The height of the zone 1 was computed from as-built cross sections. The ratio for Dixon Canyon Dam averages approximately 2.2 percent and for Spring Canyon Dam averages approximately 1.6 percent. Variations can be expected due to differing placement moisture contents. Generally, the ratio is relatively constant for each row, which indicates that the settlement is occurring as the result of embankment or foundation compression.

### C. Piezometric Surface

The piezometric surface typical of Soldier Canyon, Dixon Canyon, and Spring Canyon Dams is shown on figure 17. This figure shows the piezometric surface in Dixon Canyon Dam. The contours of equal pressure are plotted incorrectly at the reservoir-embankment contact. The purpose of the figure is to indicate that the phreatic surface is still advancing through the embankment. The measured piezometric surface does not correspond with a steady-state seepage condition as would be predicted using Casagrande's procedure.

The piezometric surface within the zone 1 material does not appear to have reached steady-state conditions. A few piezometers, especially numbers 7 and 64, show an increasing trend, starting in approximately 1978. The increasing trend may be an indication of the advance of the phreatic surface in the embankment. Plots of piezometers numbered 7 and 64 are shown on figure 18. Most of the piezometers show fluctuations with reservoir water surface. Piezometers such as

No. 65 and 66, which are downstream of the crest and approximately 80 feet above the embankment foundation contact, show no response to reservoir water surface. These piezometers may indicate that the phreatic surface has not advanced to that location. The location of piezometers 7, 64, 65, and 66 are marked on figure 17 with a box around the piezometer numbers. The settlement versus time is a function of the advance of the phreatic surface through zone 1.

#### IV. Laboratory Testing

##### A. Consolidation Tests

During May 1984, samples of zone 1 materials from a drill hole in Spring Canyon Dam were obtained for one-dimensional consolidation tests to determine if additional settlement can occur due to saturation. The samples were selected for testing based on their density, moisture content, and depth within the embankment. The samples were first loaded to approximately the overburden pressure and then saturated. After saturation, additional increments of load were applied to complete the consolidation curves for each sample. All the samples were loaded to a maximum of 200 lb/in<sup>2</sup>. Table 5 summarizes the results of these tests.

Table 5

Sample No.	Depth below embankment surface (ft)	Estimated overburden pressure (lb/in <sup>2</sup> )	Percent strain due to wetting	Percent strain at 200 lb/in <sup>2</sup>
6ly-11	59-61	35	0.3	6.8
6ly-16	109-111	100	1.3	8.0
6ly-21	159-161	150	0.1	4.7

Plots of the test results for samples No. 6ly-11 and 6ly-16 are shown on figures 19 and 20, respectively. Sample No. 6ly-16 at a depth of approximately 110 feet had significant additional settlement on saturation. The other two samples had very little additional settlement on saturation; however, sample No. 6ly-11 from a depth of approximately 60 feet below the crest of the dam may have experienced the same settlement on saturation as sample No. 6ly-16 if the load at saturation had been the same. Since figures 19 and 20 are presentative of the one-dimensional consolidation test data, a plot of the test results for sample No. 6ly-21 is not shown. The small quantity of vertical strain upon saturation in sample No. 6ly-21 as compared with that of samples No. 6ly-11 and 6ly-16, may be an

indication that saturation and settlement at a depth of approximately 161 feet has occurred. For samples of similar materials placed at the same moisture content and dry of optimum moisture, the magnitude of the settlement or strain that occurs on saturation varies with the applied pressure. The higher the applied pressure, the greater will be the settlement on saturation. Since the same amount of total settlement will occur for samples placed dry or wet of optimum moisture, the effect of placing materials too dry of optimum moisture is to delay the settlement until after saturation occurs. The behavior of zone 1 materials from Horsetooth Reservoir shown on figures 19 and 20 is similar to that shown on figure 21(10) from Embankment Dams Engineering. Figure 21 from the literature shows a material that decreased in void ratio on saturation. The samples of zone 1 materials shown on figures 19 and 20 also decreased in void ratio when saturated. The behavior is indicative of that which occurs upon saturation of materials placed too dry of optimum moisture content become saturated. That is, a material placed too dry of optimum moisture will settle upon saturation with no increase in vertical stress.

#### B. Dispersive Testing

In May 1984, tests for dispersive clay were performed on two samples of zone 1 material from Spring Canyon Dam. The pinhole, double hydrometer, and crumb tests were performed. From these tests, it was concluded that the clays comprising zone 1 materials at Horsetooth Reservoir are nondispersive.

#### C. Petrographic Analyses

Samples of embankment materials were found to be composed primarily of quartz (40 to 65 percent) and clay minerals (12 to 40 percent) (smectite and illite/mica) with minor feldspar, calcite, hematite, and miscellaneous minerals.

Two samples of foundation materials were analyzed. These samples were obtained from the embankment-foundation contact. A sample of weathered rock was composed primarily of calcium montmorillonite (70 to 75 percent) with lesser amounts of quartz (20 percent) and traces of illite/mica, feldspar, calcite, hematite, and miscellaneous minerals. A sample of unweathered rock from below the weathered rock previously discussed was primarily composed of calcite (75 to 80 percent), quartz (10 to 15 percent), clay minerals (4 to 6 percent), and miscellaneous minerals.

### V. Discussions

#### A. Settlement of Zone 1 Materials

The zone 1 materials at Horsetooth Reservoir were compacted dry of optimum moisture content. Laboratory testing was accomplished to define the range of placement moisture contents such that immediate

settlement due to saturation was reduced and slope instability due to high construction pore water pressures was avoided. However, it appears that the results of the tests were not used to control the placement moisture to avoid immediate settlement due to saturation. According to Sherard (5), earth compacted without sufficient moisture has three detrimental properties:

1. The initial permeability is relatively high.
2. Saturation can cause important settlements.
3. The material is stiff and brittle.

Seepage through the zone 1 materials at Horsetooth Reservoir has not been a problem. The permeability of the zone 1 materials was low initially, as evidenced by the slow development of the phreatic surface within the embankment. Apparently, the material was placed to a high density and the moisture content was not dry enough to have an effect on the permeability.

The magnitude of the settlement that has occurred at the Horsetooth Reservoir Dams is not unusual. However, the rate of settlement, although decreasing with time, has not decreased as would be expected for a structure with nearly 35 years of operation. Total settlements would be less if the material had been compacted at optimum moisture content. The primary effect of the low placement water contents at these structures has been to delay the settlement to a later time when saturation occurs. The effect is similar to that shown on figure 22 (4). Two curves of load versus strain are shown on this figure. One curve shows a dry material and the other shows a wet material. The dry material experiences smaller strains as the material is loaded. However, when saturation occurs, immediate settlement, due to wetting, takes place and any further strain occurs along the wet material deformation curve. If saturation of a dry material occurs, the total strain will eventually equal that which would occur if the material had been wet. The dry material and the wet material have the same initial density and void ratio. In the embankment, saturation occurs as the wetting front advances, which here is very slowly, due to the low permeability of the zone 1 materials. This may account for the continued settlement at the Horsetooth Reservoir Dams. The following evidence suggests that the settlement is the result of placing zone 1 materials too dry of optimum moisture content:

1. Steady-state phreatic surface has not developed within the embankment.
2. Some piezometers indicate a steady increase starting in approximately 1975.
3. Rates of settlement show a shift from higher at upstream settlement measurement points to higher at downstream settlement measurement points. (Consider only the two rows of settlement measurement points near the crest.)

4. Recent laboratory tests on undisturbed samples of zone 1 material taken from Spring Canyon Dam show immediate settlement due to saturation after loading to overburden pressure.

5. Nearly 50 percent of the zone 1 material was placed at moisture contents drier than recommended by laboratory report No. EM-152. The report provided a range of moisture contents below which immediate settlement on saturation would occur.

6. Consolidation tests conducted on zone 1 material prior to construction show no immediate settlement on wetting. These materials were placed at optimum moisture and dry density prior to testing.

7. The foundations of these dams are composed of sandstones and shales. These materials are not subject to the settlement of the magnitude experienced in the Horsetooth Reservoir Dams.

If the materials had all been placed in a range from 2 percent dry to 1 percent wet of optimum moisture content, a major portion of the consolidation that occurred would have taken place during construction and the magnitude of total settlement would be less. Some settlement would still have occurred; however, that now occurring would probably be in the secondary consolidation portion of the e-log p curve and the rate of settlement would be lower than presently observed.

Sherard (5) presents six examples of dams that have experienced substantial differential settlements which resulted in cracking of the embankment. Sherard found three factors that were associated with the cracking of the embankments. These were low construction moisture content, construction materials consisting of silts and silty clays, and steep abutments. Three of the dams studied by Sherard were constructed during the late 1940's at the same time as the Horsetooth Reservoir Dams. These dams have zone 1 cores constructed of silty clays. When these soils are compacted dry, they have the necessary combination of rigidity and settlement on saturation to be inclined to crack. Sherard found silts and silty clays with  $0.02 < D_{50} < 0.15$  millimeter and  $PI < 15$  are most susceptible to the danger of cracking. Also, Sherard states that clay soils with  $D_{50} < 0.02$  millimeter and  $PI > 20$  experience larger postconstruction settlement due to saturation when compacted dry than the silty clays described above. Further, Sherard states that these clay soils apparently have sufficient deformability when compacted dry to sustain shear strains due to differential settlements without cracking.

As shown in Sherard's work, substantial cracking can result from the differential settlement caused by low compaction moisture content. Cracking was observed on the crest of Dixon Canyon Dam. Perhaps this cracking was a result of compaction too dry of optimum moisture instead of along the contact of zone 1 and zone 1A as discussed earlier in this report.

The zone 1 materials used to construct the Dixon Canyon and Spring Canyon Dams have a D<sub>50</sub> size ranging from 0.015 to 0.037 and plasticity index ranging from 11 to 17. From table 3, the average plasticity index is 12.8 in Dixon Canyon Dam and 14 in Spring Canyon Dam. These parameters are within the range for zone 1 materials which Sherard would expect cracking of the embankment if compacted at low moisture contents. However, these materials are at the lower end of the criteria for material susceptible to cracking and may have sufficient deformability to sustain shear strains without cracking. This borderline condition may indicate why cracking occurred on Dixon Canyon Dam and not on Spring Canyon Dam, while both dams experienced similar total settlements.

Apparently, the zone 1 materials placed in the Horsetooth Reservoir Dams were well compacted to water contents not extremely dry of the limiting moisture content for immediate settlement due to saturation. These conditions have limited the amount of settlement and contributed to delaying or spreading out of the settlement that has occurred.

#### B. Rockfill

The rockfill materials were placed without compaction by vibratory rollers and adding moisture to aid compaction. A portion of the settlement that occurred during first filling of the reservoir is due to settlement of the rockfill. Also, a portion of the settlement measured at downstream settlement measurement points may be the result of saturation of the rockfill by rainfall. The magnitude of the settlement in the rockfill is unknown; however, settlement of this material has likely taken place.

The longitudinal cracking on the crest of Dixon Canyon Dam provides some evidence that settlement of the rockfill has contributed to the deformation measured at this structure. Although no cracking was reported at the other Horsetooth Reservoir Dams, settlement of the rockfill has likely contributed to the measured deformations since the rockfill at all the structures was placed dry without vibratory compaction.

The measured settlements at Horsetooth and Soldier Canyon Dams are approximately one-half of that measured at Dixon Canyon and Spring Canyon Dams. This may be the result of differences in zoning of the structures (see figs. 2 through 5). For example, Dixon and Spring Canyon Dams have downstream rockfill zones. Since these structures have wide zone 1 cores, differences in zoning probably has a minor effect on the settlement observed. Horsetooth and Soldier Canyon Dams have downstream zones composed of sand, gravel, and cobbles, which were compacted by sluicing methods. In addition, zone 1 materials at Dixon Canyon and Spring Canyon Dams were placed drier of optimum water content than zone 1 materials placed in Horsetooth and Soldier Canyon Dams.

## VI. Camber Requirements

From figure 22(4), the increase in compression resulting from wetting under load may be seen to be very nearly the same as the difference between the amounts of compression of initially wet and initially dry specimens. This concept is used to estimate the additional settlement that can be expected at the Horsetooth Reservoir Dams. Each of the recent one-dimensional consolidation tests was plotted on the same graph of void ratio versus log pressure. These plots are shown on figure 23. An initially dry consolidation curve was approximated by using the consolidation curves prior to saturation. An initially wet consolidation curve was approximated by using the consolidation curves after saturation. The initially dry and initially wet consolidation curves were determined by the best fit of the data. The void ratio difference between the initially dry and initially wet consolidation curves at the same pressure or loading can be used to estimate the amount of compression that will occur on saturation for that pressure. The test data for the sample located at a depth of 160 feet plotted well below the remainder of the data. This sample had a lower initial void ratio and has probably experienced all the compression settlement due to saturation at some time in the past. If the test data for this sample are replotted with overburden pressure added to the load increments, the curve plots as nearly an extension of the initially wet consolidation curve indicating a potential for a higher void ratio in the past.

The difference in void ratio between the initially dry and the initially wet consolidation curves for a particular pressure was used to compute the strain at a particular depth within the embankment. The strain ( $\Sigma$ ) was computed from the following equation:

$$\Sigma = \frac{\Delta e}{1 + e_0}$$

where  $\Delta e$  is the difference in void ratio at the beginning of saturation and at the end of saturation,  $e_0$  is the void ratio at the beginning of saturation.

From in situ moisture contents for samples from Spring Canyon Dam, the embankment materials appear to be saturated below a depth of 140 feet. Below a depth of 140 feet, it is assumed that all compression settlement due to saturation has occurred. The average height of the embankment measured from the crest that has yet to compress is 70 feet.

The curve shown on figure 24 was developed by computing the strain from the difference in void ratio of the initially dry and initially wet consolidation curves shown on figure 23. The depth into the embankment shown on figure 24 is estimated from the load shown on figure 23. The load shown on figure 23 is divided by the average unit weight of the zone 1 material which is 130 lb/ft<sup>3</sup> to find the depth in the embankment where a particular strain occurs. The average strain is found from figure 24. The average strain is multiplied by the full depth of the

embankment that has yet to settle. From figure 24, the strain at 70 feet is equal to 0.0108. The estimated settlement(s) is computed from the following equation:

$$S = H \left( \frac{\Delta e}{1 + e_0} \right)$$

where H is the height of the embankment yet to compress (140 ft).

The settlement due to compression on saturation is estimated to be 1.5 feet at Dixon Canyon and Spring Canyon Dams. Because the rate of settlement and the measured settlement at Horsetooth and Soldier Canyon Dams have been approximately one-half of that observed at Dixon Canyon and Spring Canyon Dams, the settlement at Horsetooth and Soldier Dams is estimated to be 0.75 foot.

Based on the settlement estimated above, 2 feet of camber will be designed for Dixon Canyon and Spring Canyon Dams and 1 foot of camber will be designed for Horsetooth and Soldier Canyon Dams.

## VII. Conclusions

- A. The total settlement of 2 to 3 percent of the embankment height is not unusual for the materials and placement moisture.
- B. Settlement patterns are not unusual.
- C. The settlement is not the result of foundation consolidation.
- D. The settlement is the result of immediate settlement upon saturation due to placing zone 1 materials too dry of optimum water content and the extended time for settlement is due to the low permeability of zone 1 materials causing slow advancement of the phreatic surface through the embankment.
- E. The camber that was originally placed on the embankment was not sufficient to accommodate settlement that has occurred.
- F. The rate of settlement is decreasing with time.
- G. Settlement is occurring in the primary consolidation portion of the void ratio-log pressure curve and may be just starting the secondary compression portion of the void ratio-log pressure curve.
- H. Part of the initial settlement is due to first filling and rainfall saturating the rockfill.
- I. Future settlement is estimated to be 1.5 feet for Dixon Canyon and Spring Canyon Dams and 0.75 foot for Horsetooth and Soldier Canyon Dams.



J. Design camber requirements of 1 foot for Horsetooth and Soldier Canyon Dams and 2 feet for Dixon Canyon and Spring Canyon Dams are sufficient to accommodate future settlements.

K. The crests of the dams need to be raised to restore constant crest elevation plus camber.

L. Settlement results from placement of the zone 1 materials too dry of optimum moisture. The process is dependent on the soil type. Clays of low plasticity and silty clays are most susceptible. Placed at moisture contents dry of optimum, these materials will collapse as the moisture content increases toward optimum.

M. The process is time dependent. The slow settlement results from the low permeability of the zone 1 materials which results in slow movement of the phreatic surface through the dam.

## REFERENCES

1. EM-152, Laboratory tests for Determination of the Placement Moisture control limits of Embankment Materials for the Horsetooth Dams. Colorado-Big Thompson Project, Colorado, Engineering and Research Center, November 10, 1947.
2. EM-73, Report of Laboratory tests on Embankment Materials, Horsetooth Reservoir Dams, Colorado-Big Thompson Project, Colorado, Engineering and Research Center, June 19, 1945.
3. Final Report on Construction of Horsetooth Reservoir Dams, Colorado-Big Thompson Project, Colorado, June 1950.
4. Nobari, E. S., and J. M. Duncan (1972), "Effects of Reservoir Filling on Stresses and Movement in Earth and Rockfill Dams," Geotechnical Engineering Report, University of California, Berkeley, January 1972.
5. Sherard, J. L. (1953), "Influence of Soil Properties and Construction Methods on the Performance of Homogeneous Earth Dams," Technical Memorandum No. 645, U.S. Bureau of Reclamation, January 1953.
6. Earth Manual, U.S. Department of the Interior, Bureau of Reclamation, second edition, 1974.
7. Holtz, R. D., and W. O. Kovacs (1981), An Introduction to Geotechnical Engineering, Prentice-Hall, Inc., Englewood Cliffs, New Jersey.
8. Sherard, J. L., R. J. Woodward, S. F. Gizienski, and W. A. Clevenger (1963). Earth and Earth-Rock Dams, John Wiley and Sons, Inc., New York, New York.
9. Terzaghi, K., and R. W. Peck (1968), Soil Mechanics in Engineering Practice, second edition, John Wiley and Sons, New York, New York.
10. Embankment Dam Engineering, Casagrande Volume, John Wiley and Sons, New York, New York.
11. "Geologic Design Data Report for Horsetooth Reservoir Dams Modification," Colorado-Big Thompson Project, Colorado, U.S. Department of the Interior, Bureau of Reclamation, 1983.
12. Heaton, R. L. (1943), Geological Report on Horsetooth Reservoir, Colorado-Big Thompson Project, Colorado, U.S. Department of the Interior, Bureau of Reclamation.

REFERENCES - Continued

13. Strauss, T. R. (1984), Laboratory Test Results - Drill Hole DH-614, Spring Canyon Dam, Geotechnical Branch Memorandum Reference No. 84-131, November 21, 1984.
14. Mitchell, J. K. (1976), Fundamentals of Soil Behavior, John Wiley and Sons, New York, New York.
15. Horsetooth Reservoir, Schedules, Specifications, and Drawings, Specifications No. 1245.

## LIST OF FIGURES

1. Settlement - log time plots for sta. 6+00, 42.5 feet u/s and 40 feet d/s on Spring Canyon Dam.
2. Horsetooth Dam, plan - elevation - sections (Dwg. 245-D-2645)
3. Soldier Canyon Dam, plan - elevation - sections (Dwg. 245-D-2649).
4. Dixon Canyon Dam, plan - elevation - sections (Dwg. 245-D-2652).
5. Spring Canyon Dam, plan - elevation - sections (Dwg. 245-D-2657).
6. Camber Requirement, drawing 245-D-4472.
7. Limiting moisture test, average material, EM-152.
8. Settlement contour plot, Dixon Canyon Dam.
9. Settlement contour plot, Spring Canyon Dam.
10. Settlement versus log-time plot, Dixon Canyon Dam, 42.5 feet upstream.
11. Settlement versus log-time plot, Dixon Canyon Dam, 42.5 feet downstream.
12. Settlement versus log-time plot, Spring Canyon Dam, 42.5 feet upstream.
13. Settlement versus log-time plot, Spring Canyon Dam, 40.0 feet downstream.
14. Settlement versus time plot, Dixon Canyon Dam, sta. 9+00.
15. Settlement versus time plot, Spring Canyon Dam, sta. 6+00.
16. Rate of settlement versus time plot, Spring Canyon Dam, sta. 6+00.
17. Pressure diagram plot for Dixon Canyon Dam.
18. Plot of piezometers, Dixon Canyon Dam.
19. Spring Canyon Dam, Sample No. 61y-11, one-dimensional consolidation test plot.
20. Spring Canyon Dam, Sample No. 61y-16, one-dimensional consolidation test plot.
21. Example of settlement on saturation for other Dams (10).
22. Plot of strain versus pressure (4).

23. Plot of one-dimensional consolidation test data, Horsetooth Reservoir Dams.

24. Plot of strain versus depth for Horsetooth Reservoir Dams.



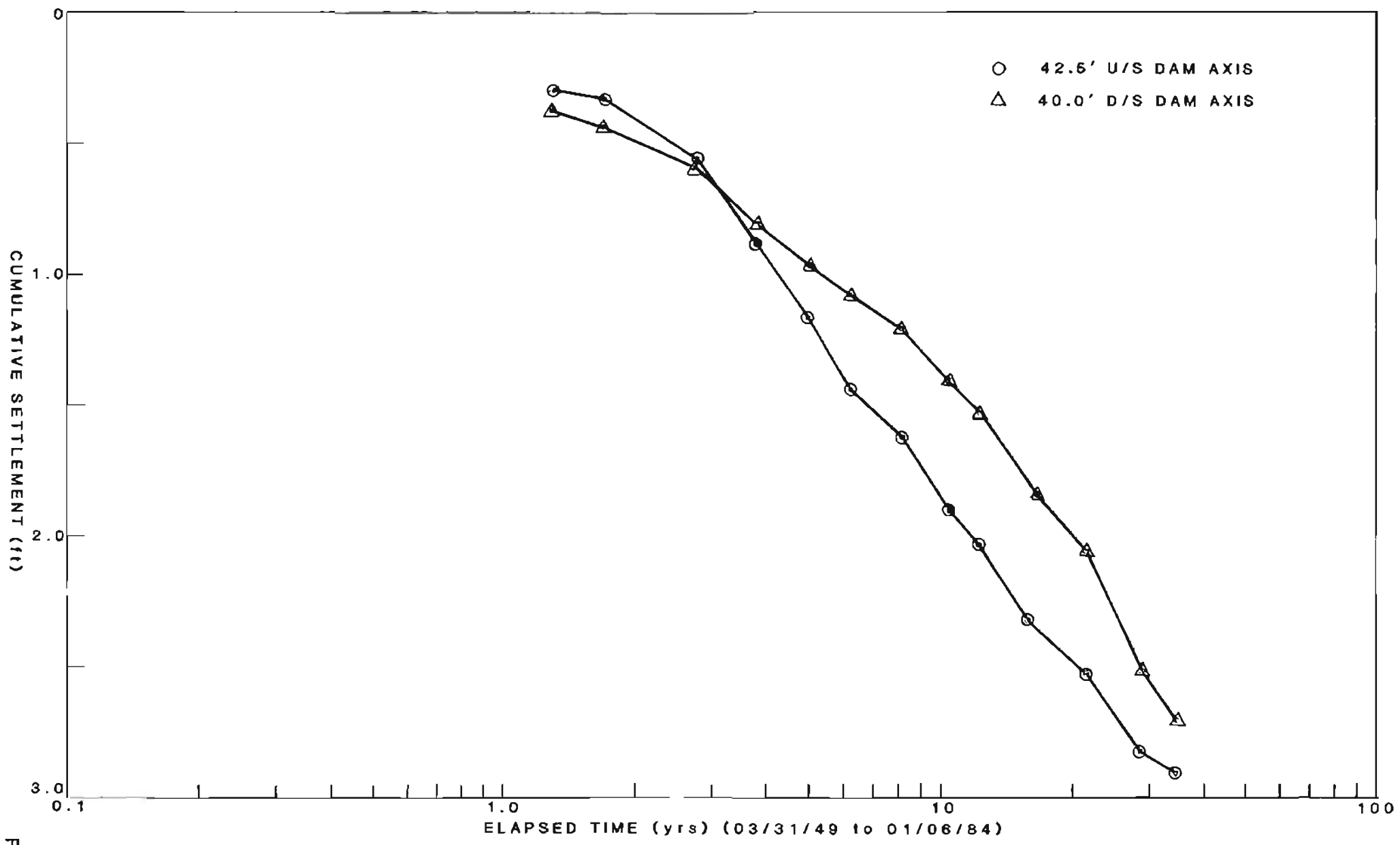

SETTLEMENT - LOG TIME PLOT SPRING CANYON DAM STATION 6+00

FIGURE 1

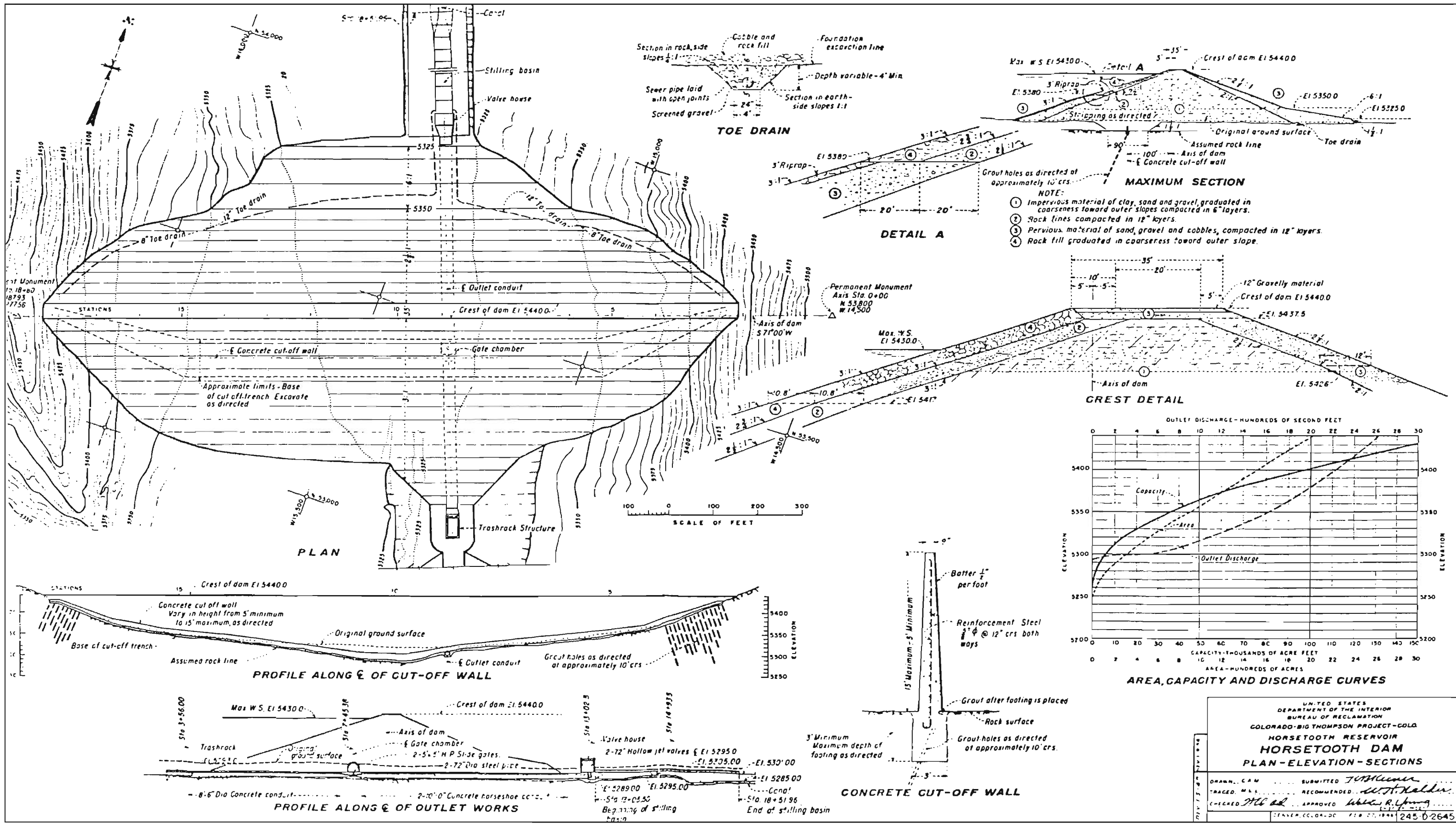

FIGURE 2



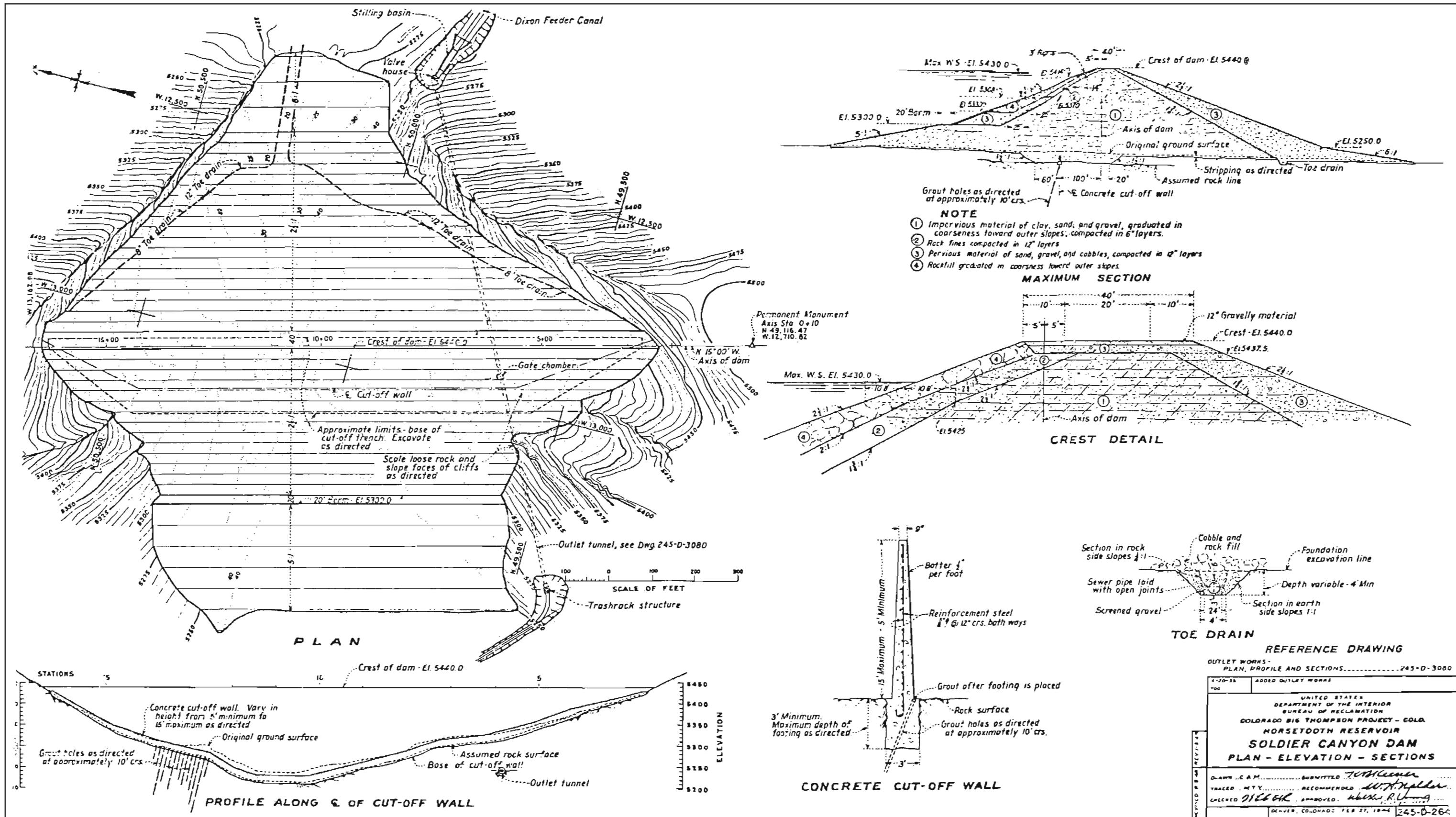
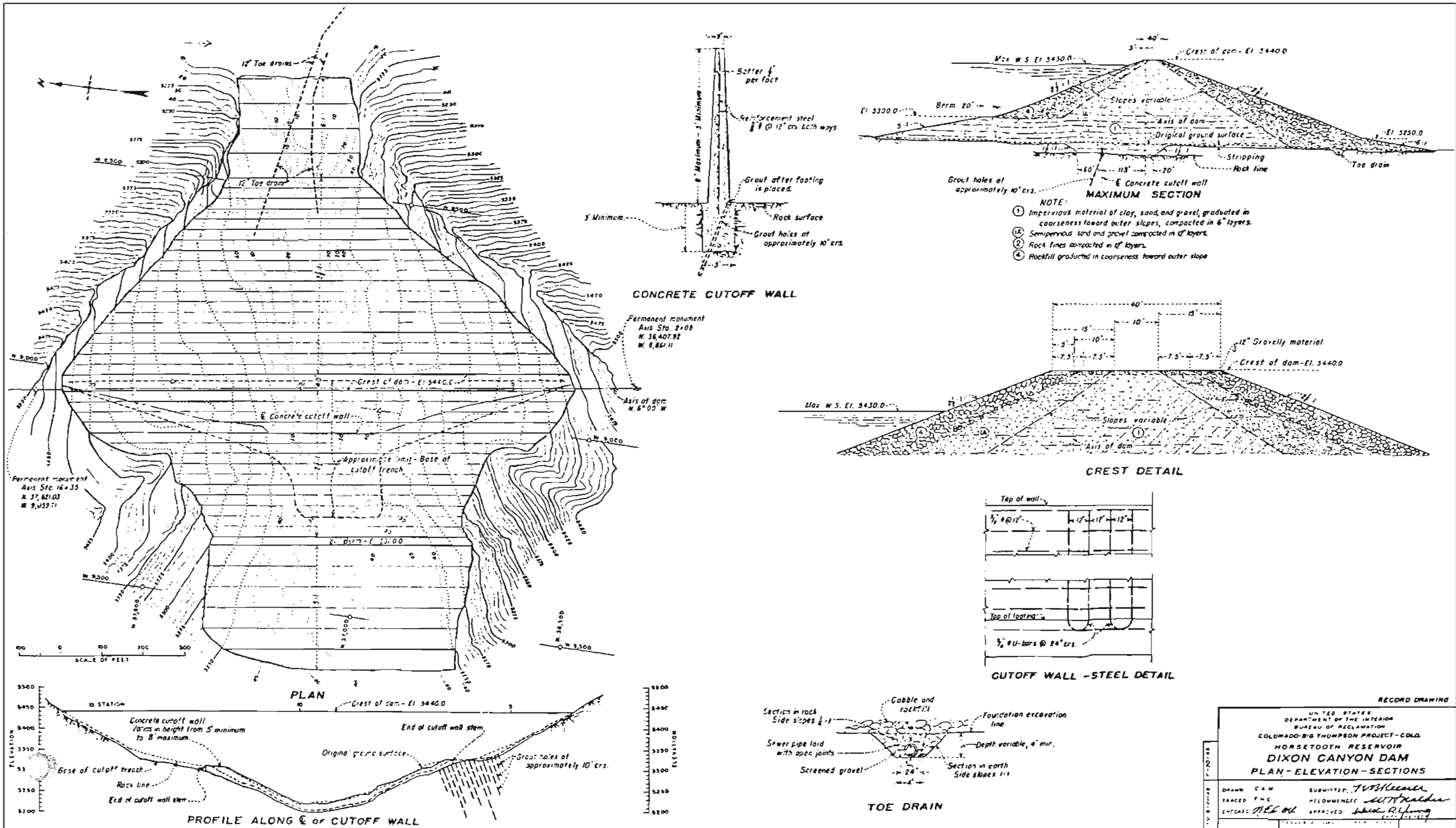

FIGURE 3



RECORD DRAWING

UNITED STATES  
 DEPARTMENT OF THE INTERIOR  
 BUREAU OF RECLAMATION  
 COLORADO-BIG THOMPSON PROJECT-COLA  
 HORSETOOTH RESERVOIR  
**DIXON CANYON DAM**  
 PLAN-ELEVATION-SECTIONS

DRAWN: S.A.M.	SUBMITTED: J.V.S. Keener
TRACKED: P.H.C.	RECOMMENDED: W.H. Keener
CHECKED: H.E.C. OR	APPROVED: [Signature]

FIGURE 4

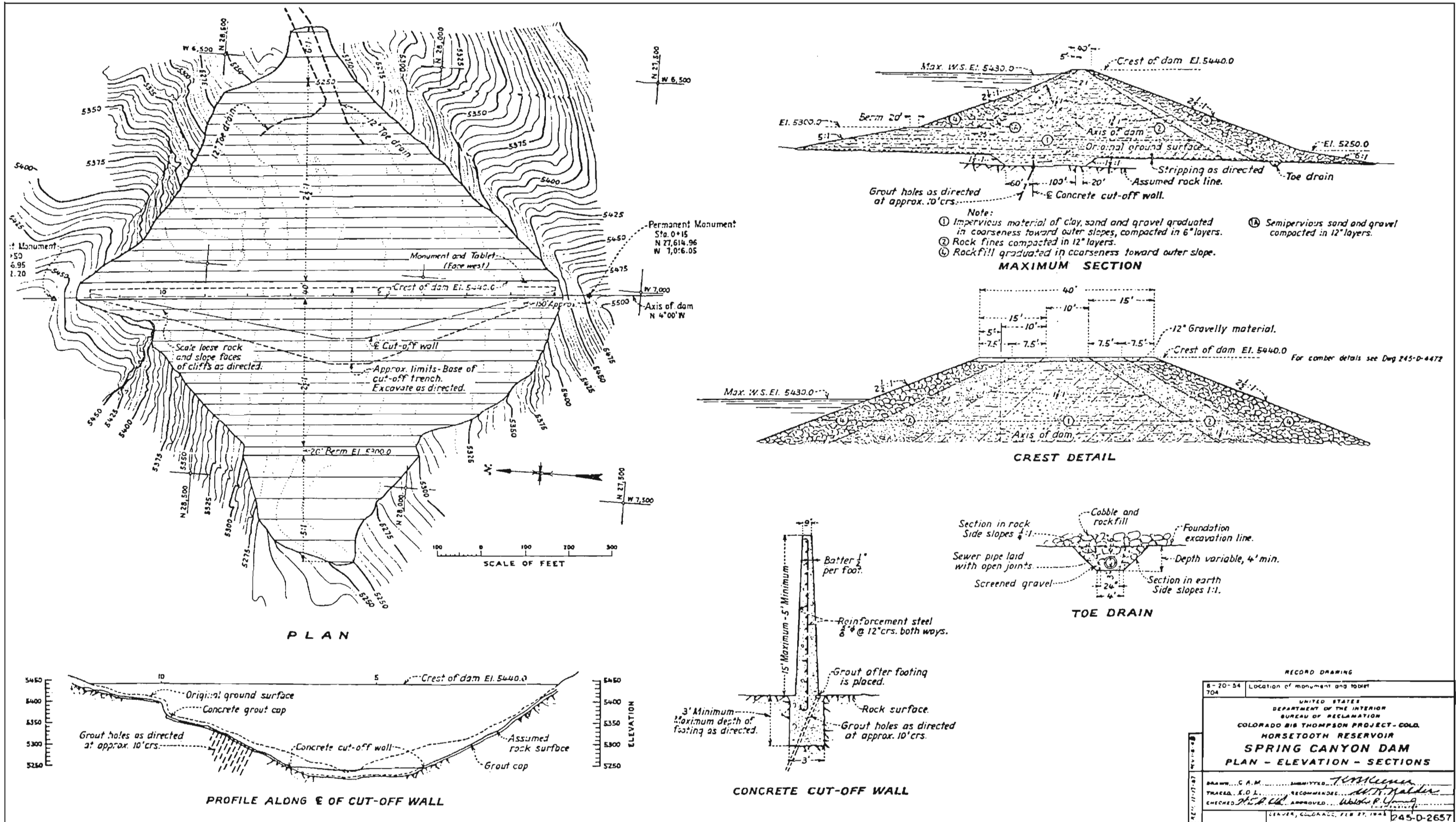

RECORD DRAWING	
8-20-34 704	Location of monument and tablet
UNITED STATES DEPARTMENT OF THE INTERIOR BUREAU OF RECLAMATION COLORADO BIG THOMPSON PROJECT - COLD HORSETOOTH RESERVOIR <b>SPRING CANYON DAM</b> PLAN - ELEVATION - SECTIONS	
DRAWN... G. A. M. TRACED... K. D. L. CHECKED... H. P. C.	SUBMITTED... Tomlinson RECOMMENDED... H. P. C. APPROVED... H. P. C.
DENVER, COLORADO, FEB 27, 1934 245-D-2657	

FIGURE 5

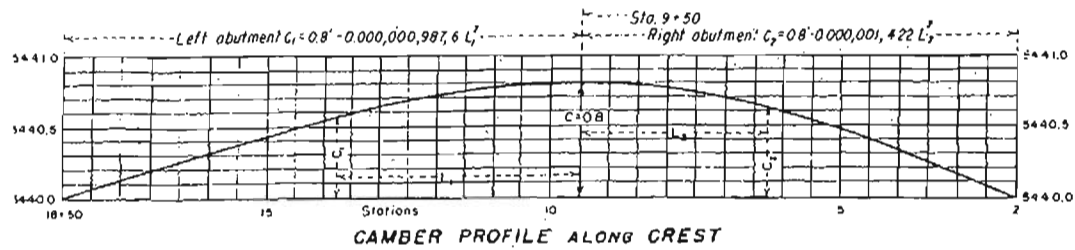

STATION	ELEV.
2+00	5440.00
2+50	.10
3+00	.20
3+50	.29
4+00	.37
4+50	.44
5+00	.51
5+50	.57
6+00	.63
6+50	.67
7+00	.71
7+50	.74
8+00	.77
8+50	.79
9+00	.80
9+50	5440.80
10+00	.80
10+50	.79
11+00	.78
11+50	.76
12+00	.74
12+50	.71
13+00	.68
13+50	.64
14+00	.60
14+50	.55
15+00	.50
15+50	.44
16+00	.38
16+50	.32
17+00	.24
17+50	.17
18+00	.08
18+50	5440.00

CREST ELEVATIONS WITH CAMBER

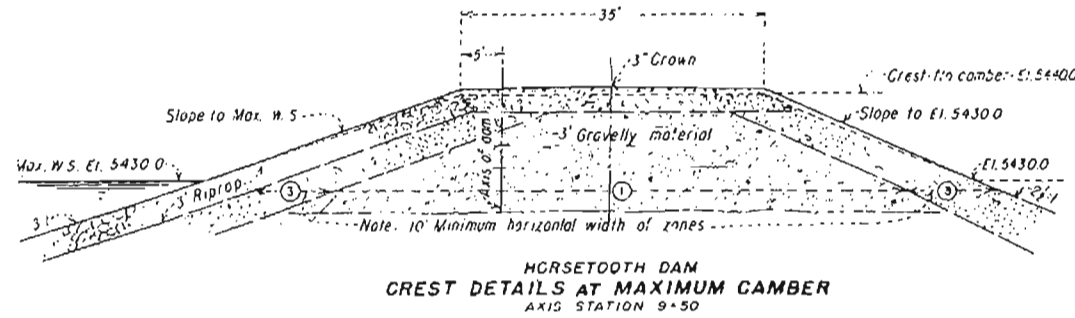

MCRSETOOTH DAM  
CREST DETAILS AT MAXIMUM CAMBER  
AXIS STATION 9+50

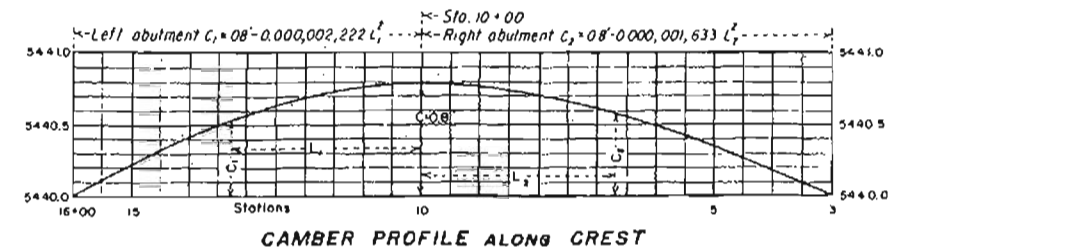

STATION	ELEV.
3+00	5440.00
3+50	.11
4+00	.21
4+50	.31
5+00	.39
5+50	.47
6+00	.54
6+50	.60
7+00	.65
7+50	.70
8+00	.73
8+50	.76
9+00	.78
9+50	.80
10+00	5440.80
10+50	.79
11+00	.78
11+50	.75
12+00	.71
12+50	.66
13+00	.60
13+50	.53
14+00	.44
14+50	.35
15+00	.24
15+50	.13
16+00	5440.00

CREST ELEVATIONS WITH CAMBER

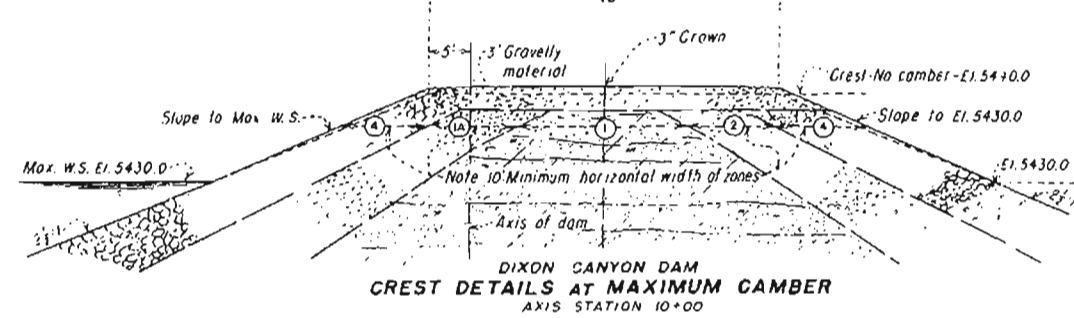

DIXON CANYON DAM  
CREST DETAILS AT MAXIMUM CAMBER  
AXIS STATION 10+00

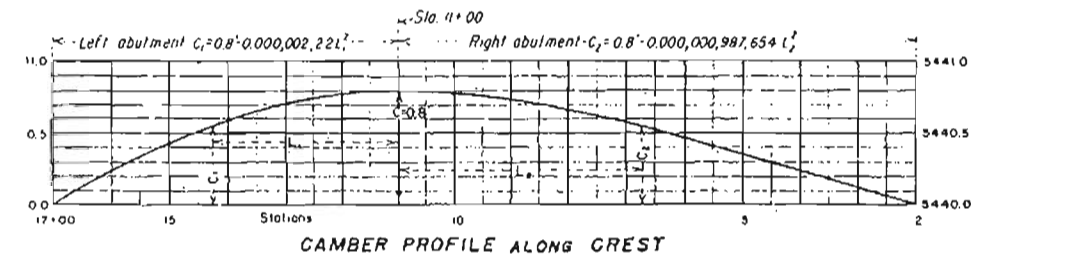

STATION	ELEV.
2+00	5440.00
2+50	.09
3+00	.17
3+50	.24
4+00	.32
4+50	.38
5+00	.44
5+50	.50
6+00	.55
6+50	.60
7+00	.64
7+50	.68
8+00	.71
8+50	.74
9+00	.76
9+50	.78
10+00	.79
10+50	.80
11+00	5440.80
11+50	.79
12+00	.78
12+50	.75
13+00	.71
13+50	.66
14+00	.60
14+50	.53
15+00	.44
15+50	.35
16+00	.24
16+50	.13
17+00	5440.00

CREST ELEVATIONS WITH CAMBER

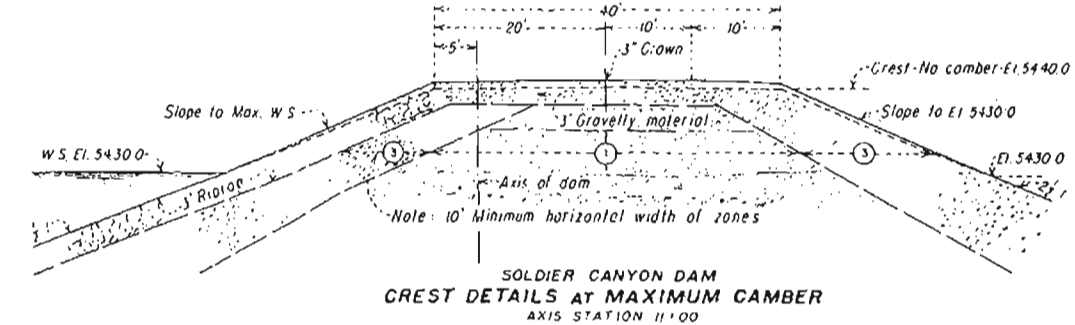

SOLDIER CANYON DAM  
CREST DETAILS AT MAXIMUM CAMBER  
AXIS STATION 11+00

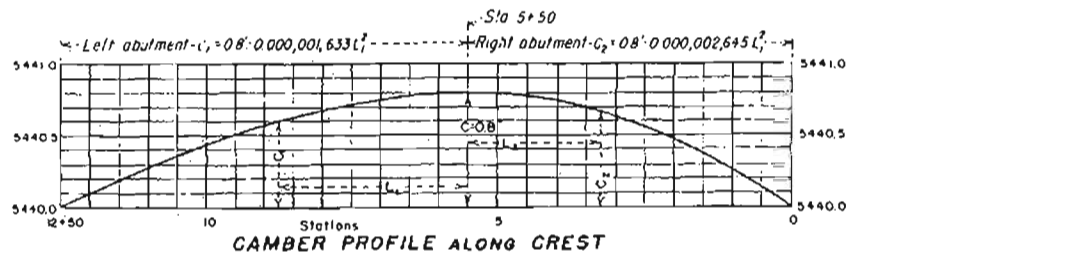

STATION	ELEV.
0+00	5440.00
0+50	.14
1+00	.24
1+50	.38
2+00	.48
2+50	.56
3+00	.63
3+50	.69
4+00	.74
4+50	.77
5+00	.79
5+50	5440.80
6+00	.80
6+50	.78
7+00	.76
7+50	.73
8+00	.70
8+50	.65
9+00	.60
9+50	.54
10+00	.47
10+50	.39
11+00	.31
11+50	.21
12+00	.11
12+50	5440.00

CREST ELEVATIONS WITH CAMBER

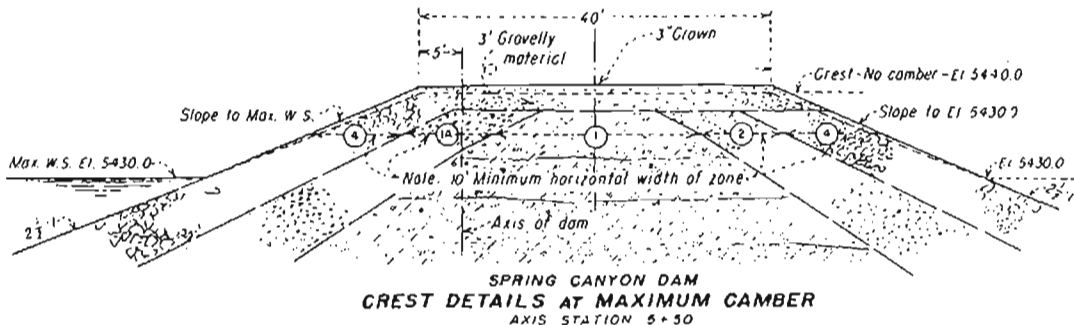

SPRING CANYON DAM  
CREST DETAILS AT MAXIMUM CAMBER  
AXIS STATION 5+50

- EXPLANATION**
- Impermeable material of clay, sand and gravel, graded in coarseness toward outer slopes, compacted in 6" layers.
  - Rock lines compacted in 12" layers.
  - Permeable material of sand, gravel and cobbles compacted in 12" layers.
  - Rockfill graded in coarseness toward outer slopes.
  - Semipermeable sand and gravel compacted in 12" layers.
- CAMBER**  
Use 0.8" maximum - 3" crown to be added to crest elevation with camber

UNITED STATES  
DEPARTMENT OF THE INTERIOR  
BUREAU OF RECLAMATION  
COLORADO BIG THOMPSON PROJECT-COLO.  
HORSETOOTH RESERVOIR  
**HORSETOOTH, SOLDIER CANYON,  
DIXON CANYON AND SPRING CANYON DAMS  
CREST AND CAMBER DETAILS**

DRAWN: C.A.M. SUBMITTED: *A.L. Rice*  
 TRACED: L.E.B. RECOMMENDED: *L.H. Alden*  
 CHECKED: *R.L. Hilde* APPROVED: *D.W. Halden*  
 DENVER, COLORADO, FEB. 7, 1948. 245-D-4472

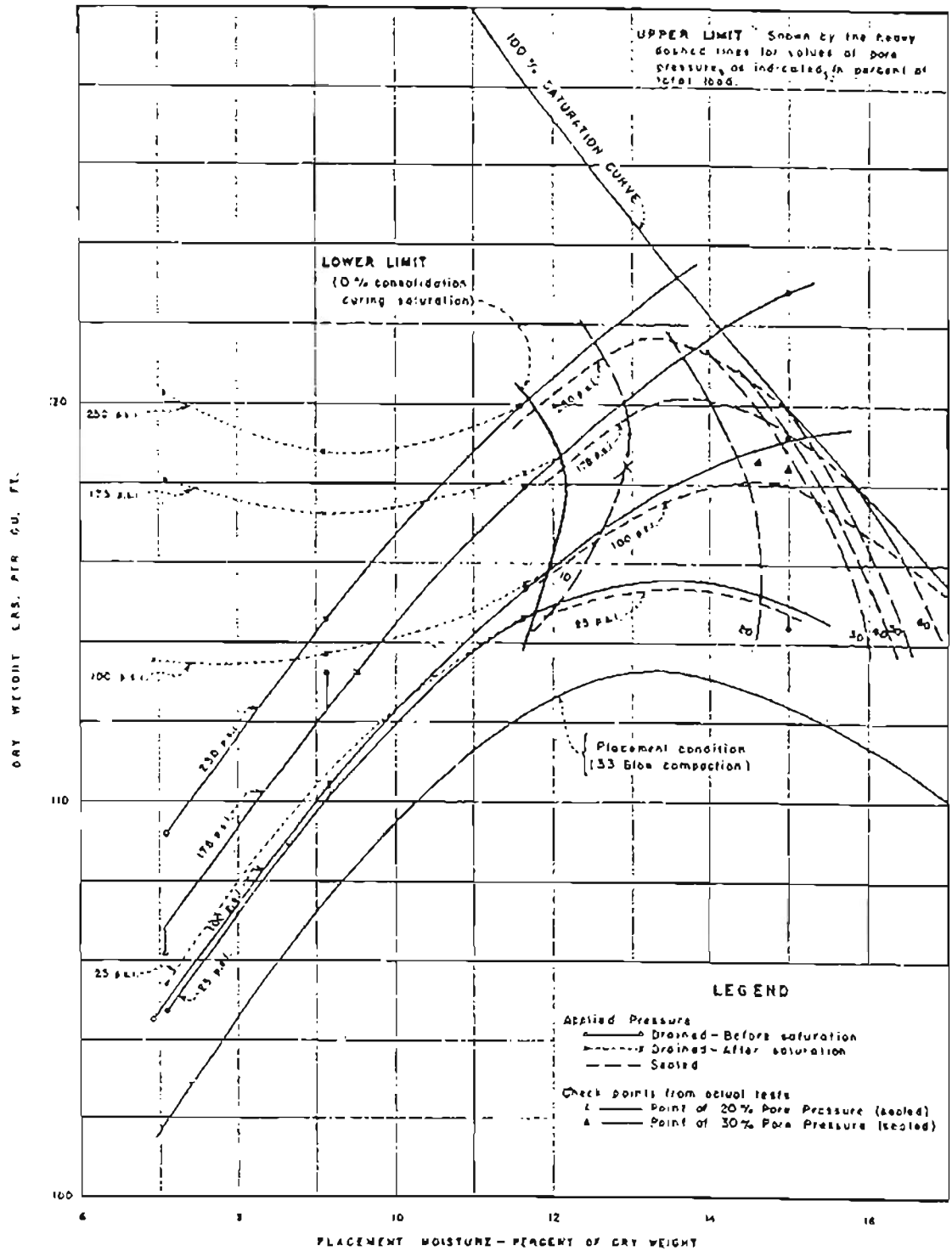

NOTES: Average Material  
 Percent clay.....17%  
 Specific gravity.....2.70

UNITED STATES  
 DEPARTMENT OF THE INTERIOR  
 BUREAU OF RECLAMATION

PLACEMENT MOISTURE DATA  
 COLORADO-BIG THOMPSON PROJECT  
**HORSETOOTH RESERVOIR DAMS**  
 PLACEMENT MOISTURE CONTROL  
 LAB SAMPLE NO. 3W-364

DRAWN BY J.C. LEBECK, L.A. P.C. DATE 8-6-59

FIGURE 7

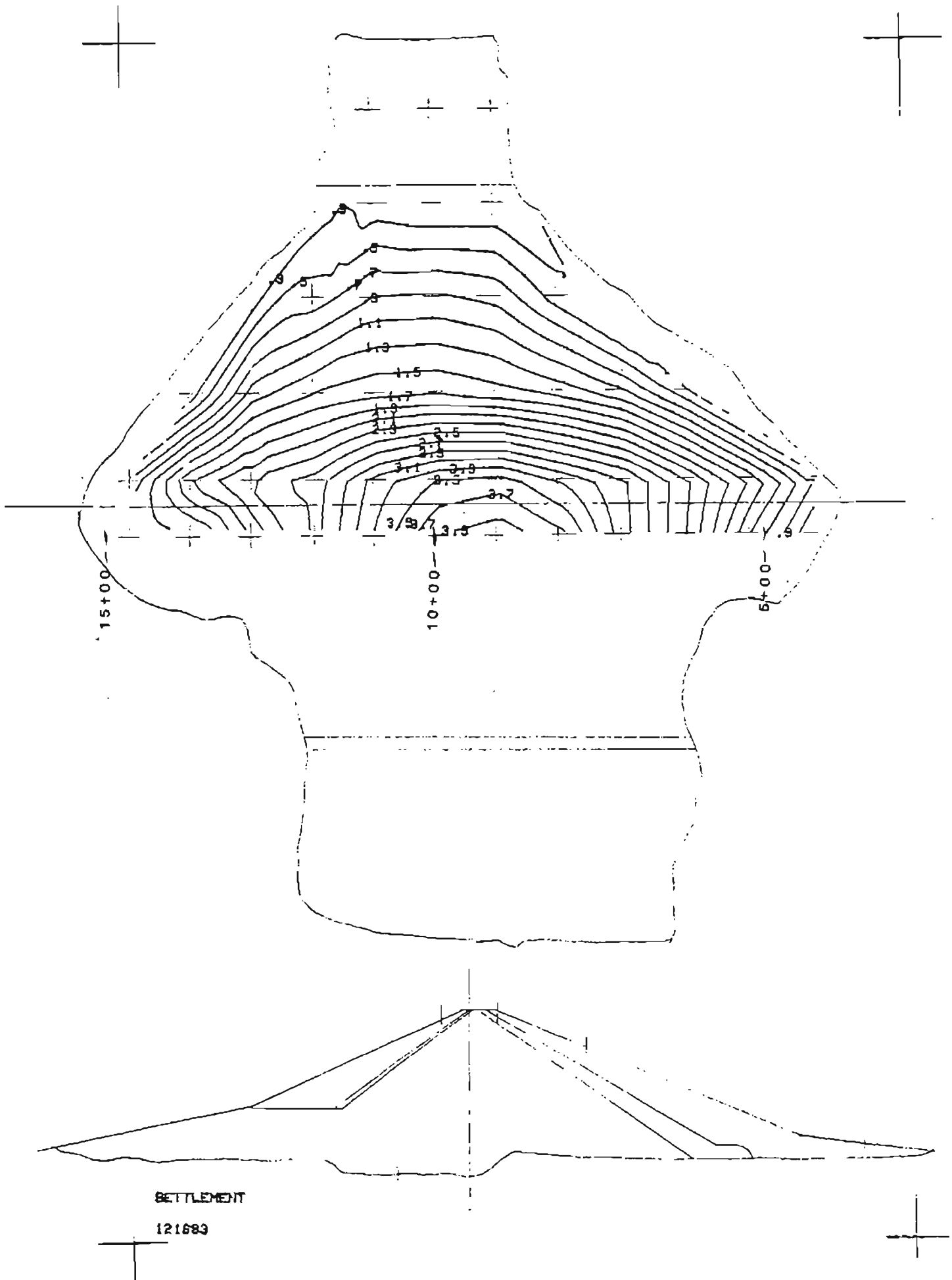

BETLEMENT  
121683

DIXON CANYON DAM

FIGURE 8

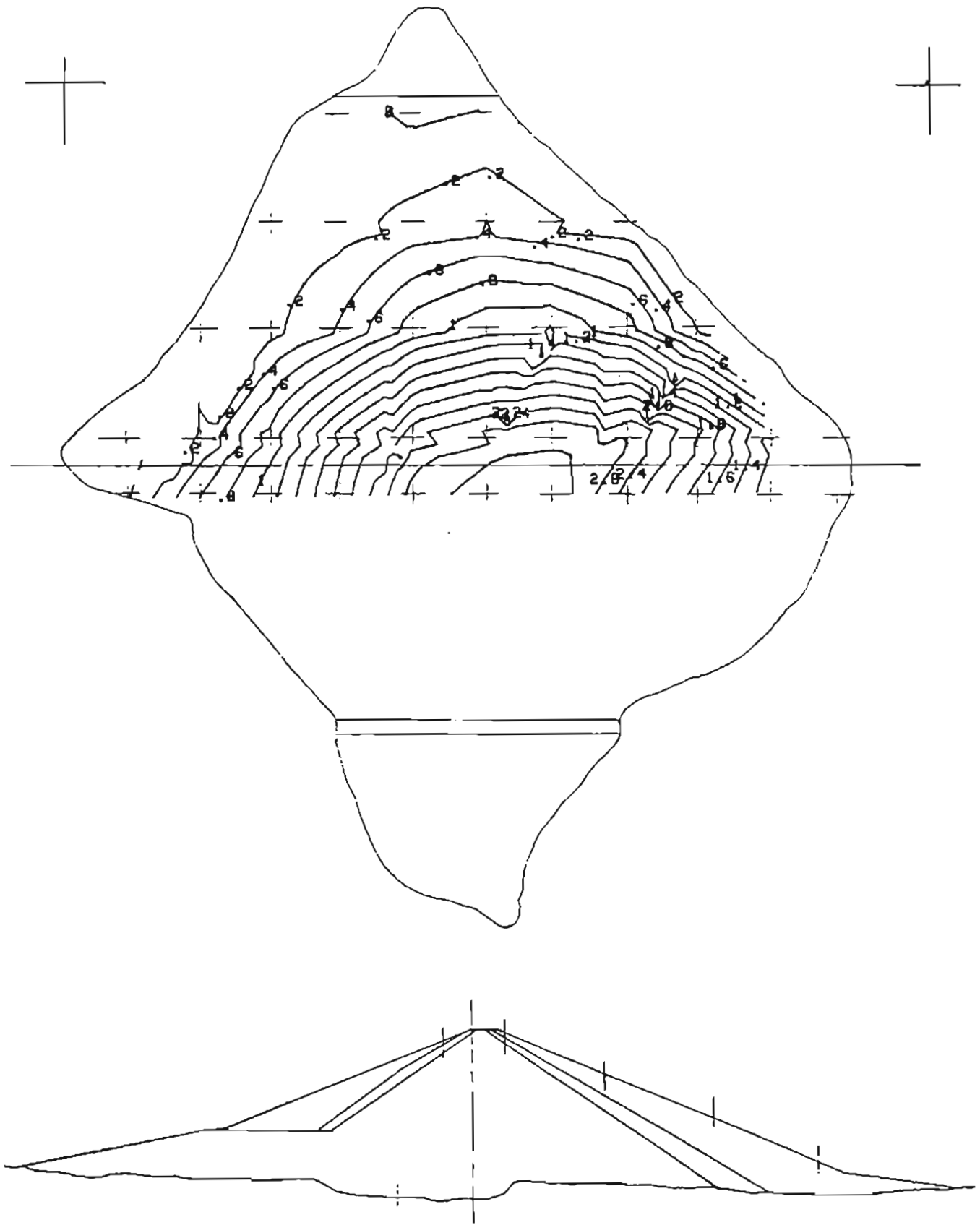

SETTLEMENT

218004

SPRING CANYON DAM

FIGURE 9

DIXON CANYON DAM MEASUREMENT POINTS 42.5 FT. U/S (SETTLEMENT)

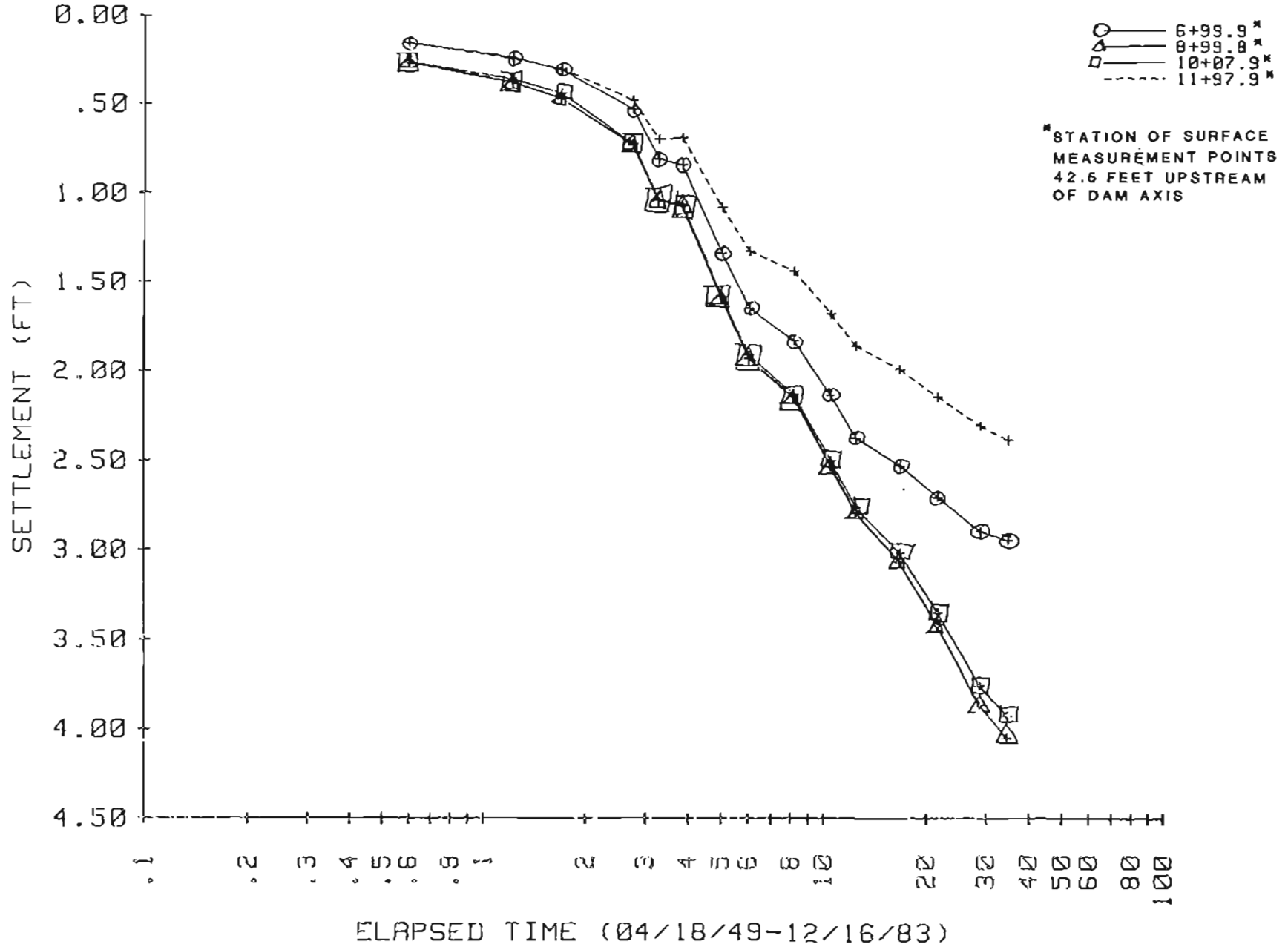

FIGURE 10



DIXON CANYON DAM MEASUREMENT POINTS 42.5 FT. D/S (SETTLEMENT)

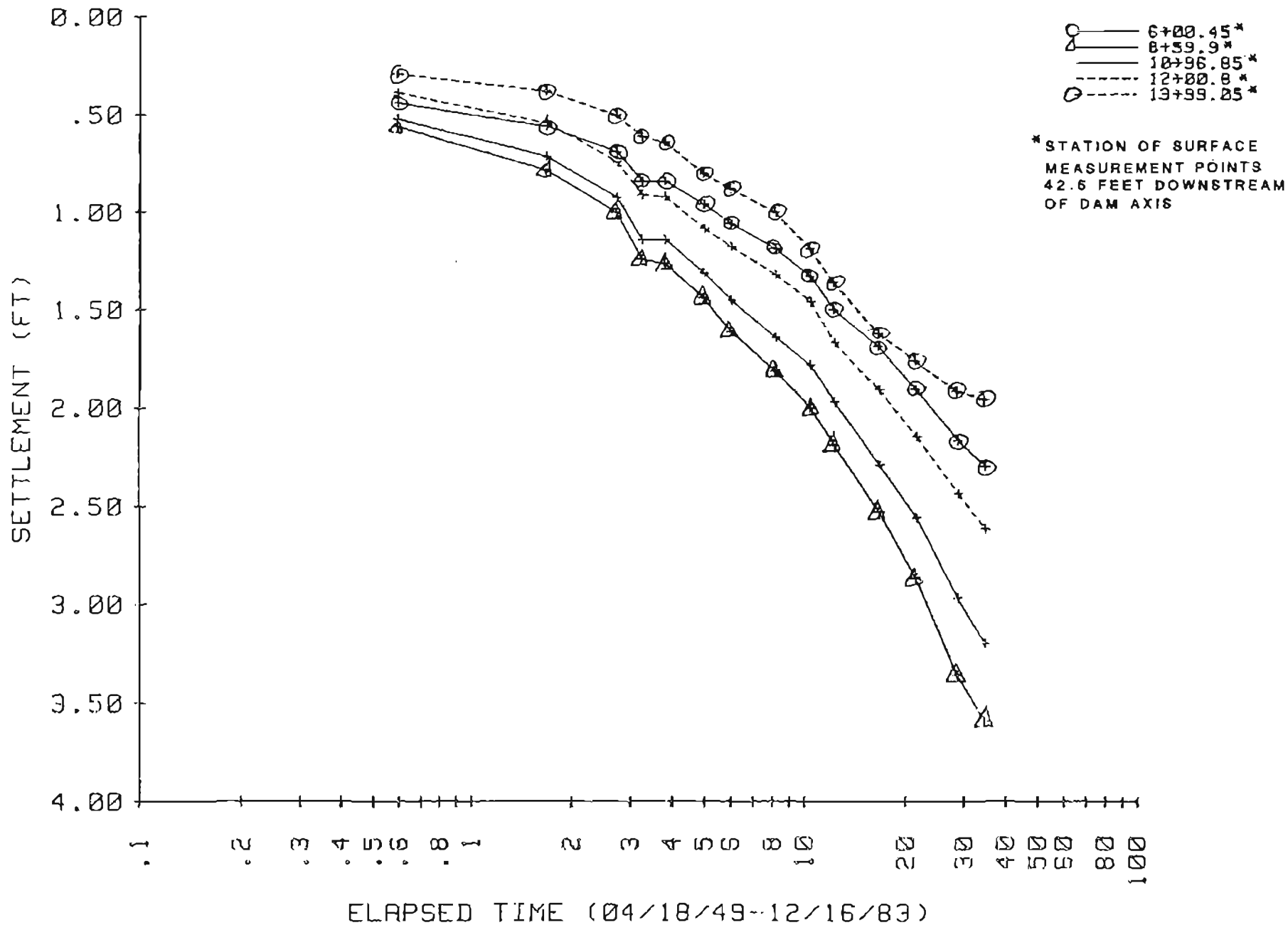

FIGURE 11

SPRING CANYON DAM MEASUREMENT POINTS 42.5 FT. U/S (SETTLEMENT)

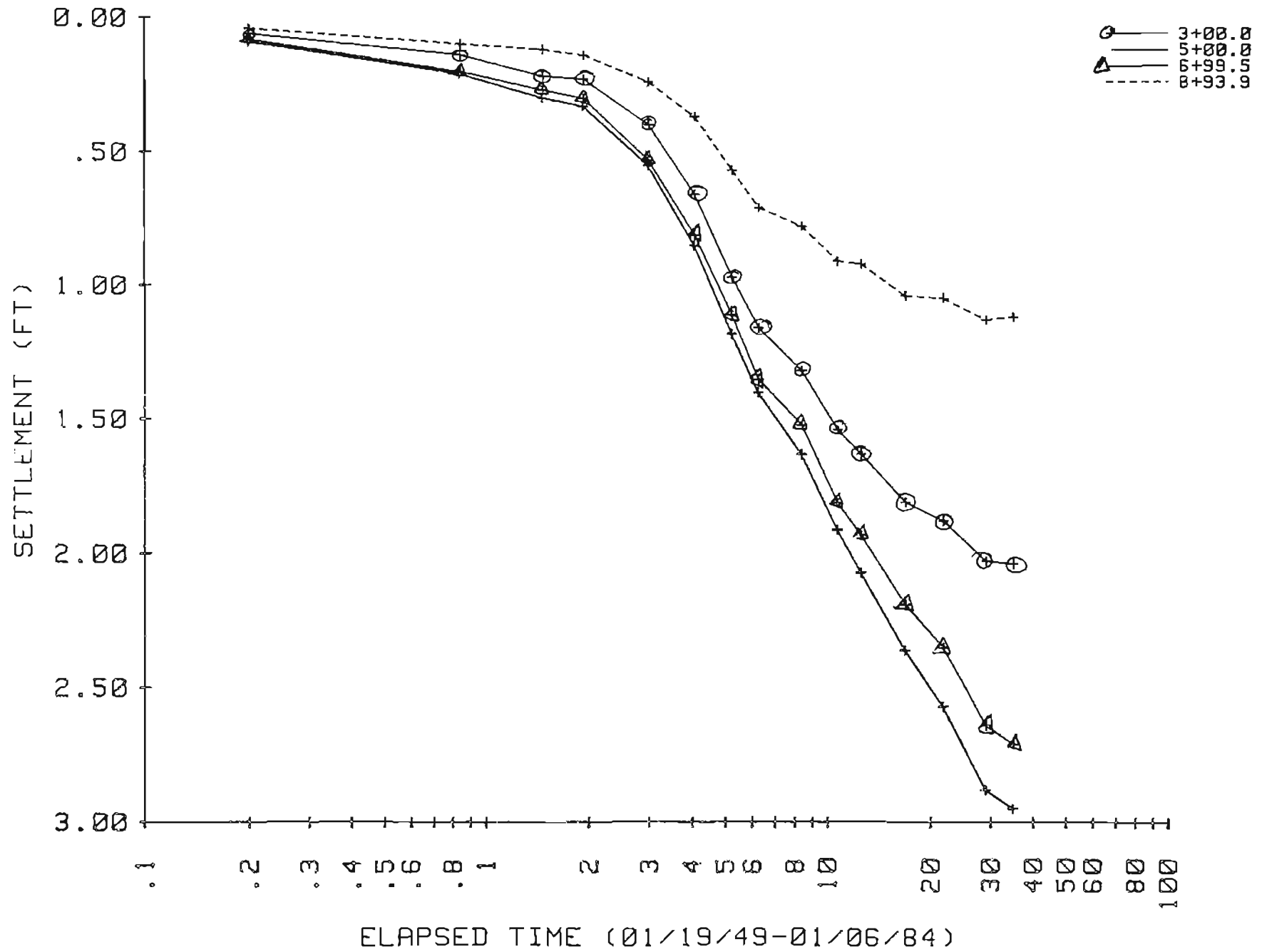

FIGURE 12

SPRING CANYON DAM MEASUREMENT POINTS 40.0 FT. D/S (SETTLEMENT)

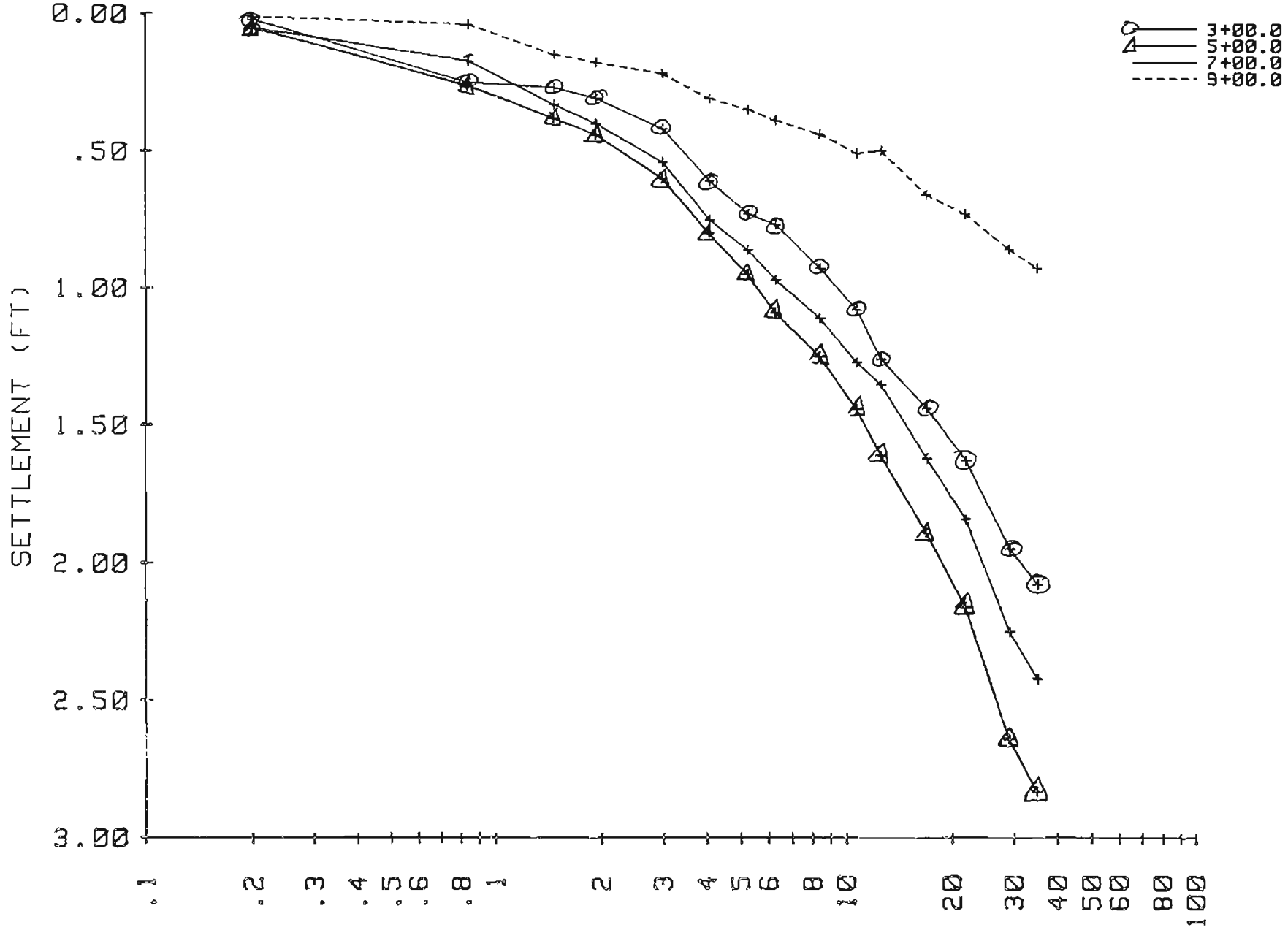

FIGURE 13

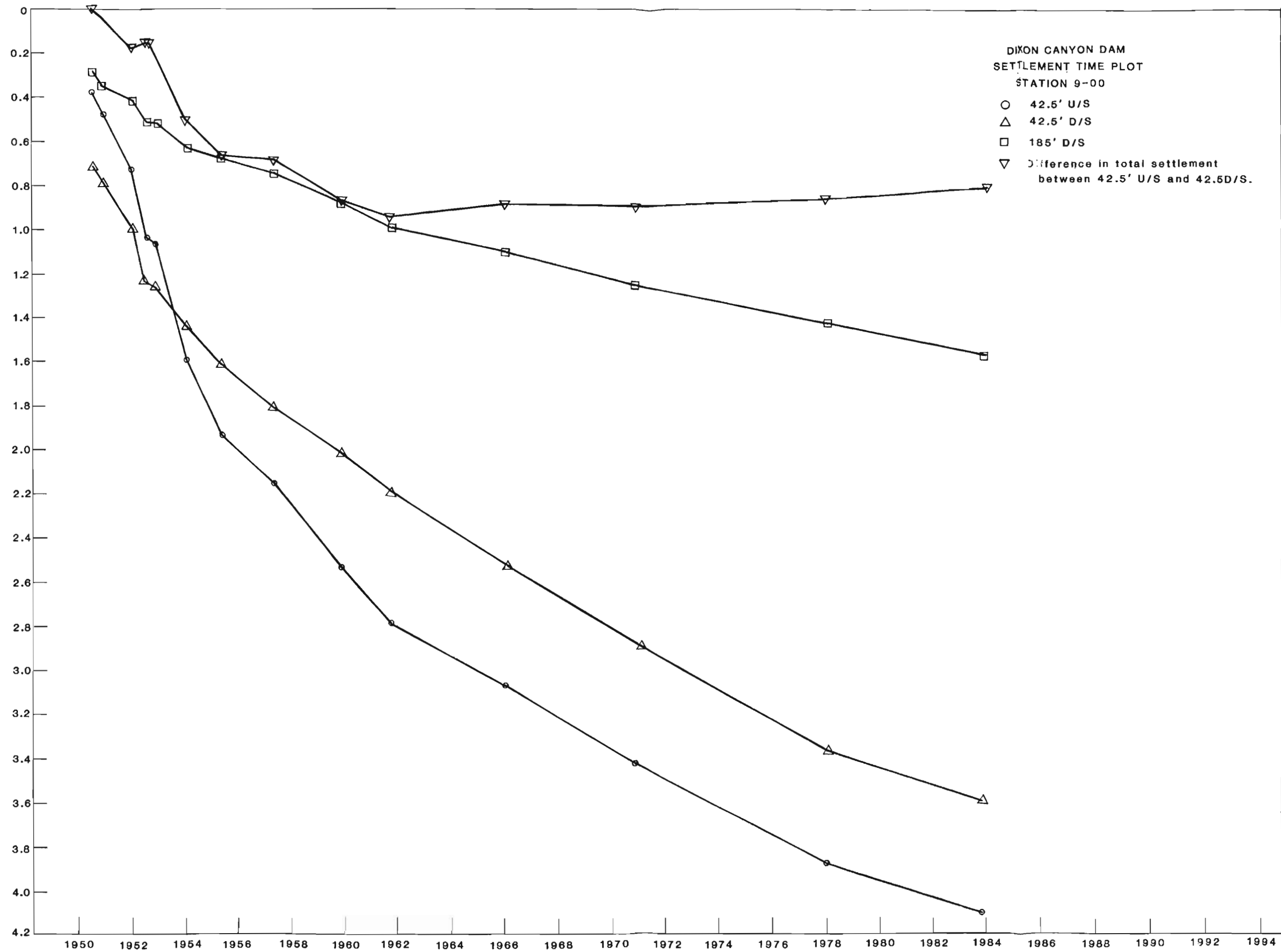
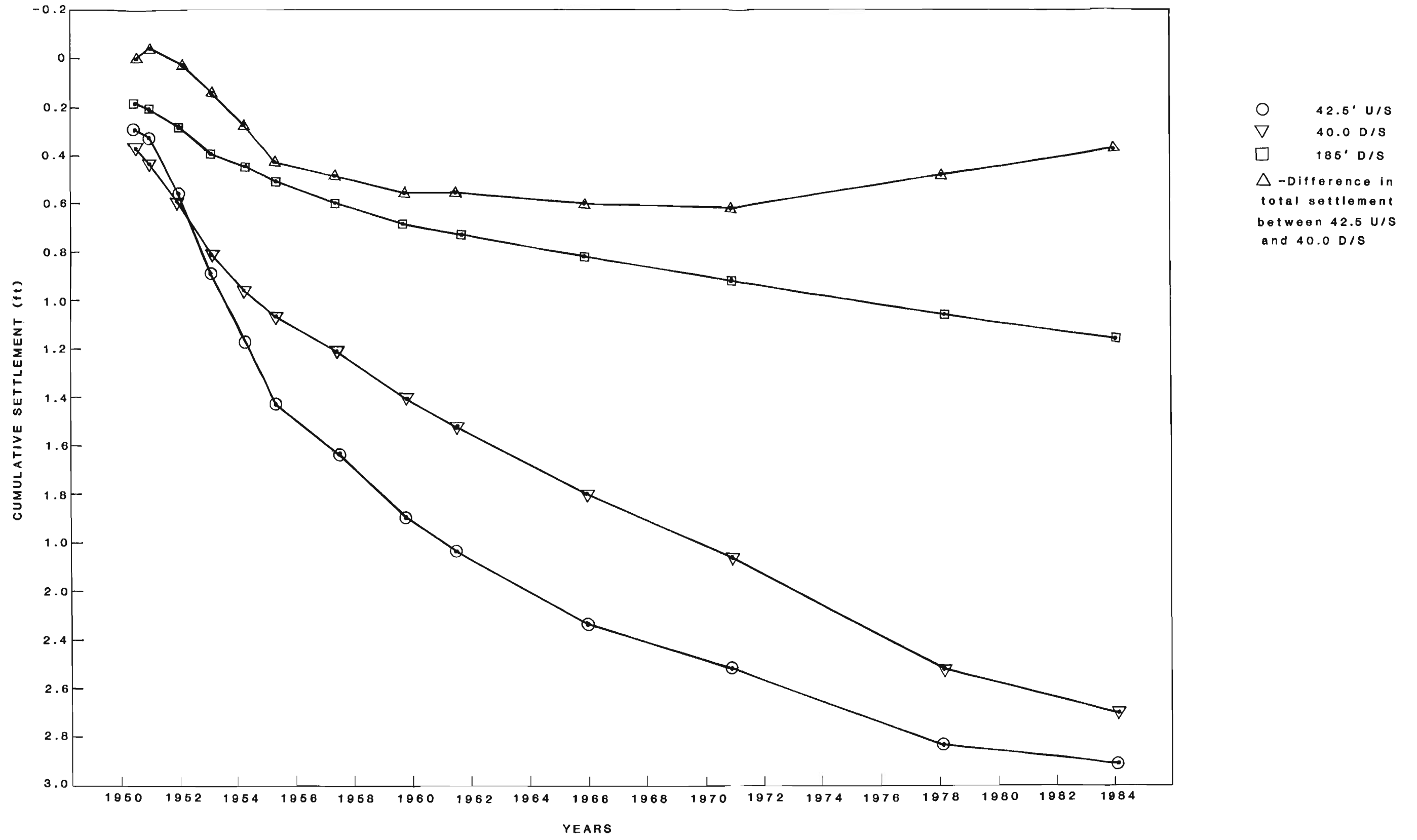
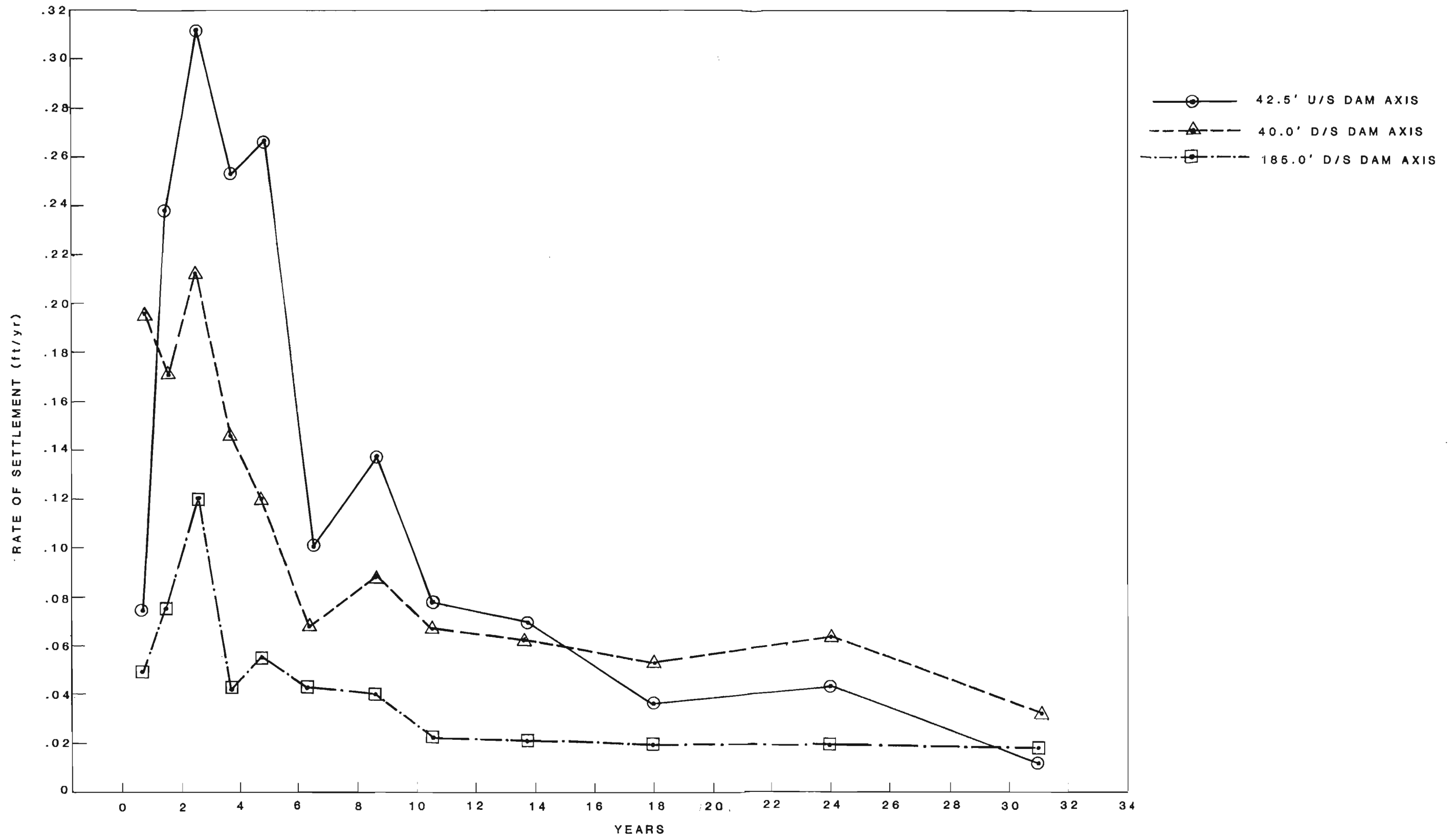

FIGURE 14



CUMULATIVE SETTLEMENT - TIME PLOT SPRING CANYON DAM STATION 6+00



RATE OF SETTLEMENT vs TIME SPRING CANYON DAM STATION 6+00

FIGURE 16

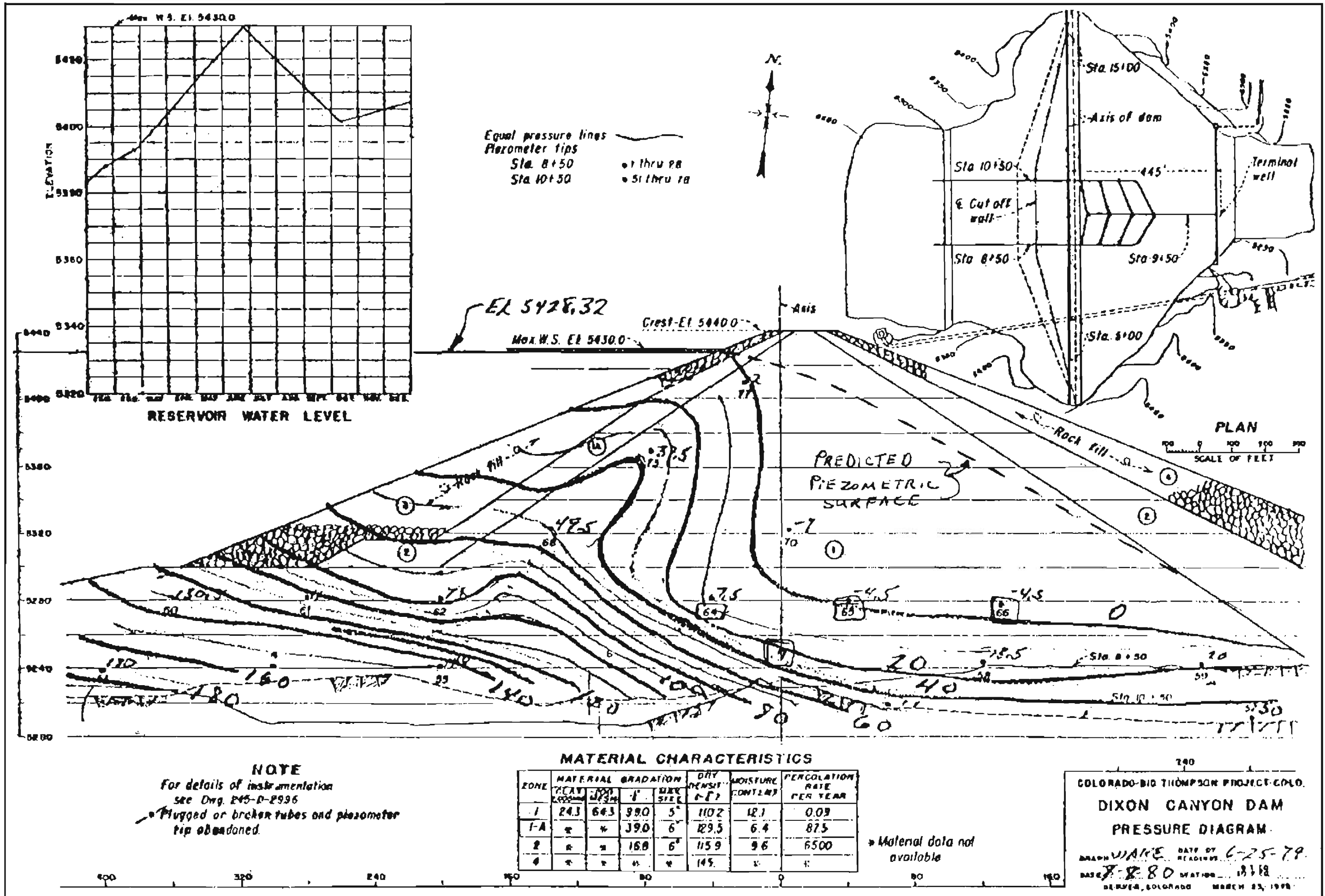
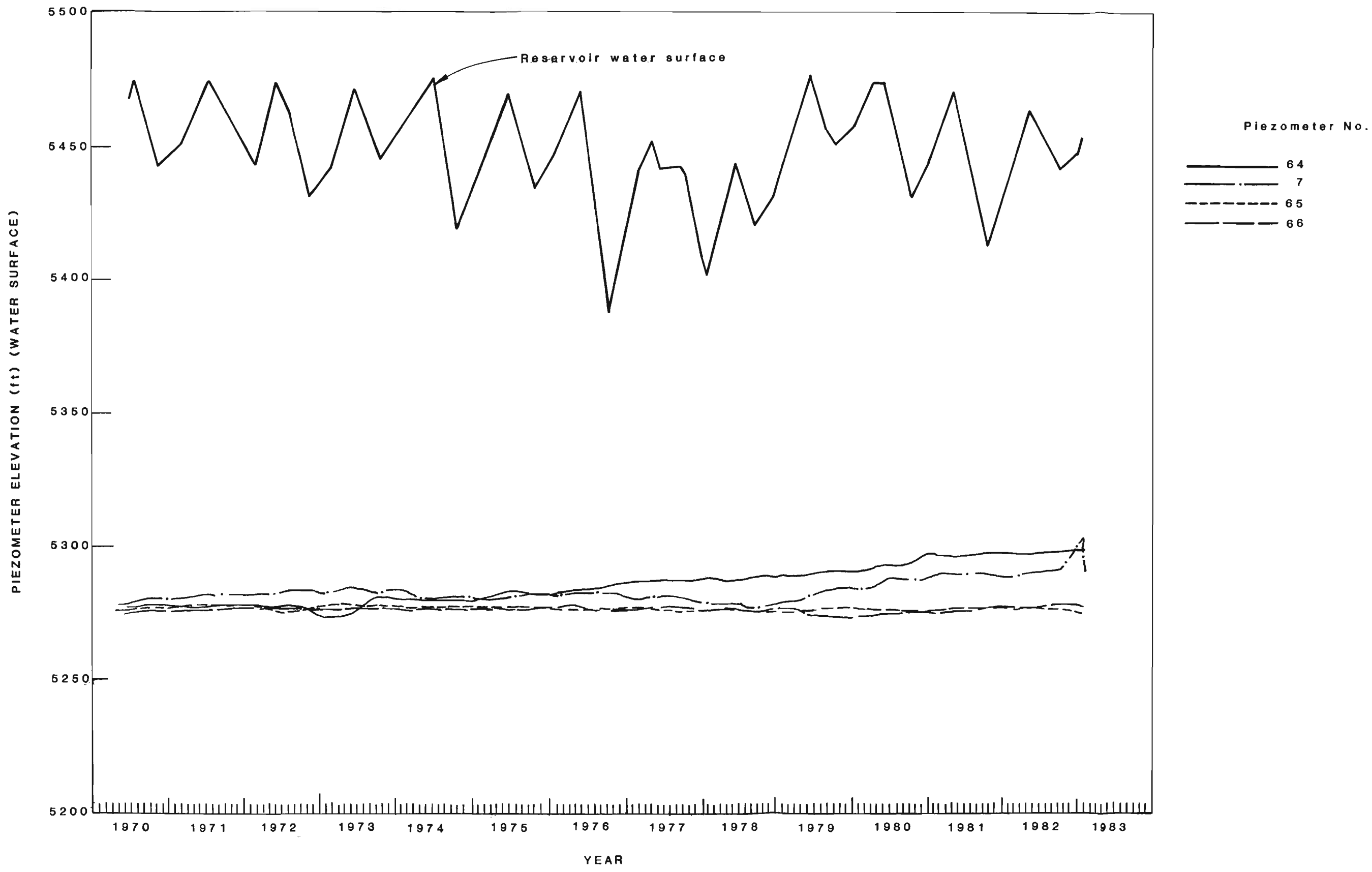

FIGURE 17



DIXON CANYON DAM HYDRAULIC PIEZOMETERS

FIGURE 18



# ONE - DIMENSIONAL CONSOLIDATION

	INITIAL	MAX LOAD
VOID RATIO	.481	.381
DRY DENSITY - lb/ft <sup>3</sup>	113.4	121.6
WATER CONTENT	14.2%	14.2%
DEGREE OF SATURATION	79.4%	100.0%

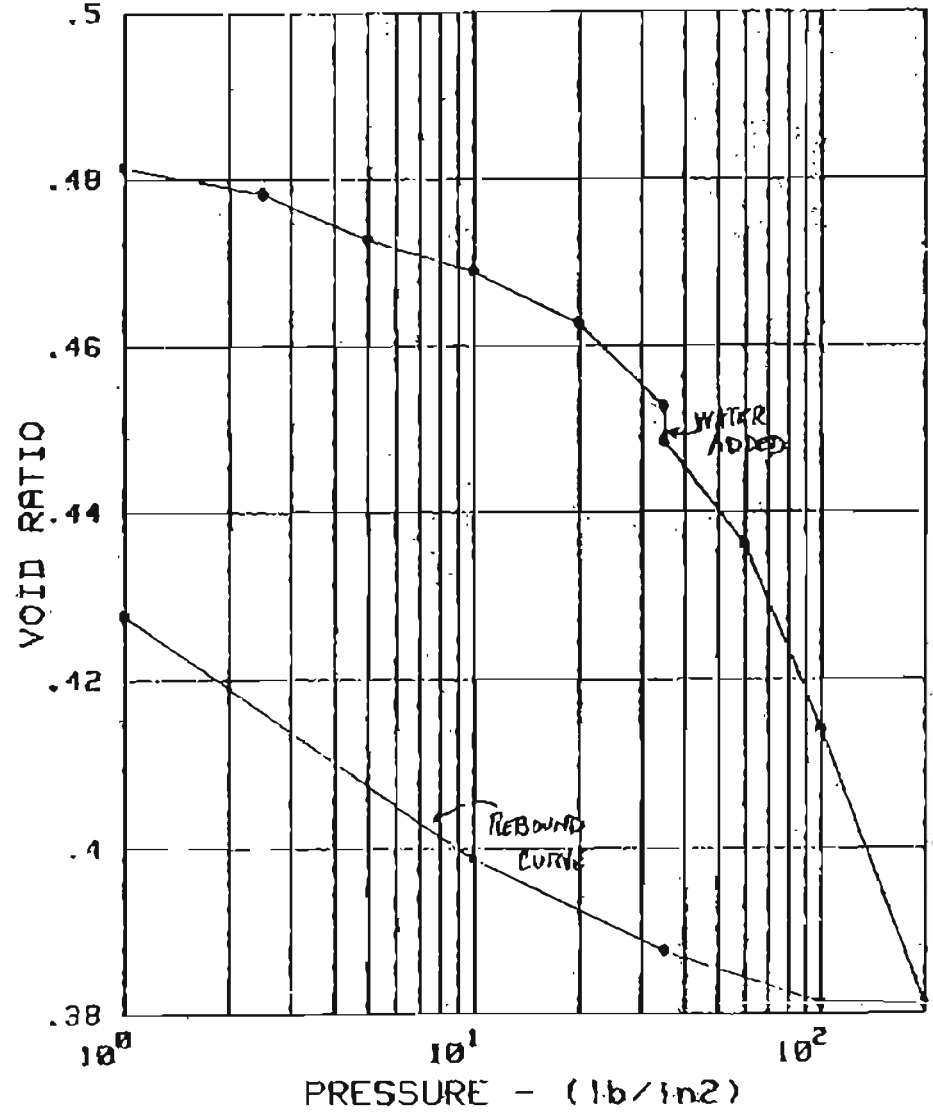
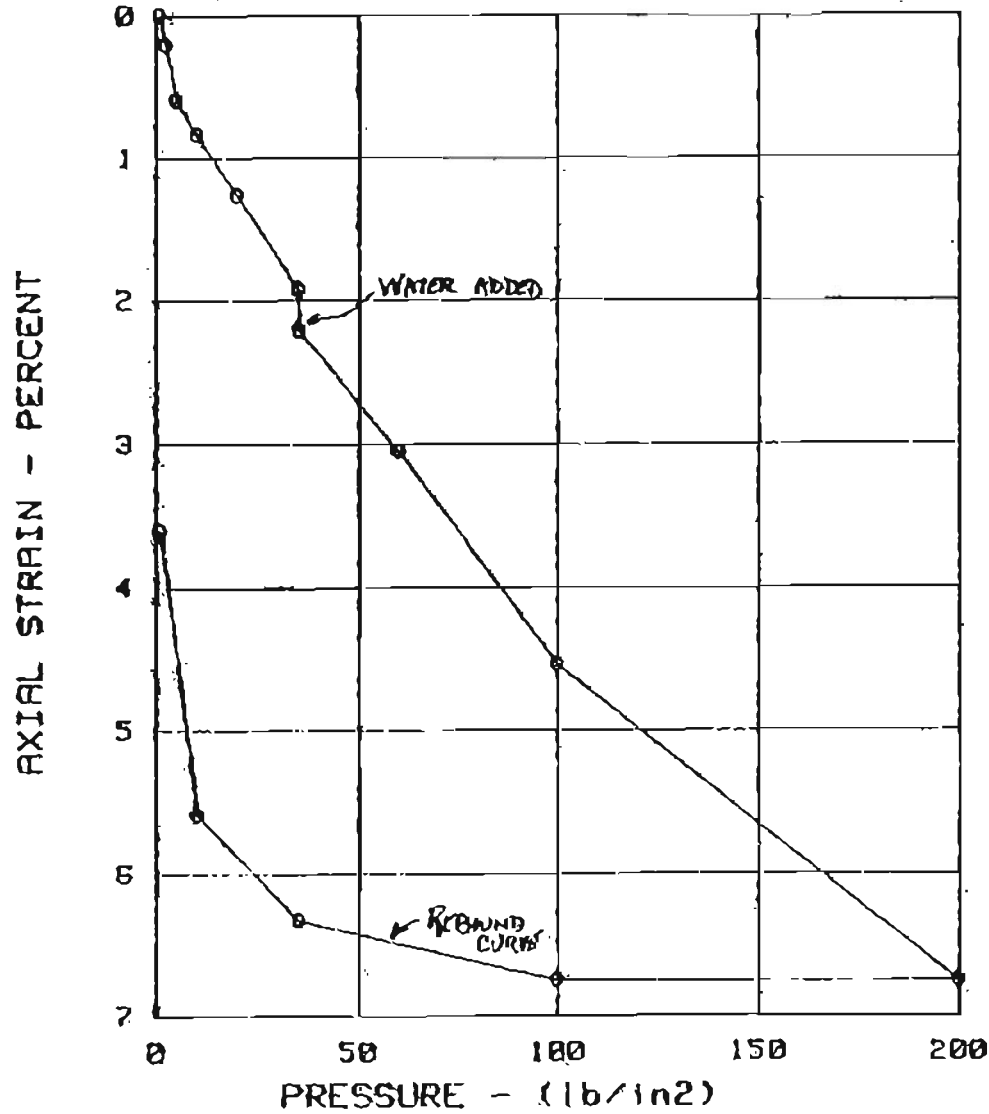

SAMPLE NO. 61Y-11	SPEC No. 51	SPEC SIZE 4.25X1.25	UNDISTURBED
CLASS SYMBOL : CL	HOLE No. : DH-614	DEPTH : 59-61	ft.

FIGURE 19

# ONE - DIMENSIONAL CONSOLIDATION

	INITIAL	MAX LOAD
VOID RATIO	.487	.367
DRY DENSITY - lb/ft <sup>3</sup>	112.9	122.8
WATER CONTENT	13.2%	13.7%
DEGREE OF SATURATION	72.9%	100.0%

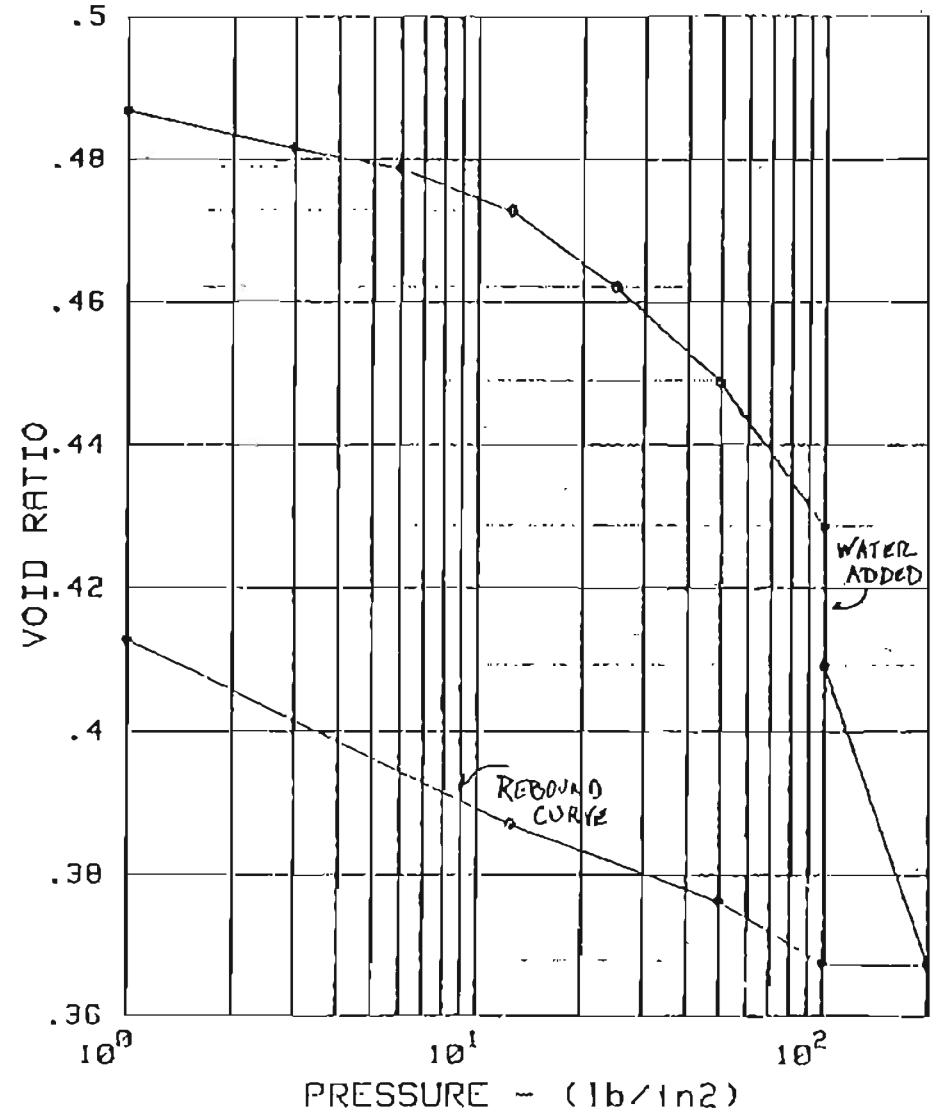
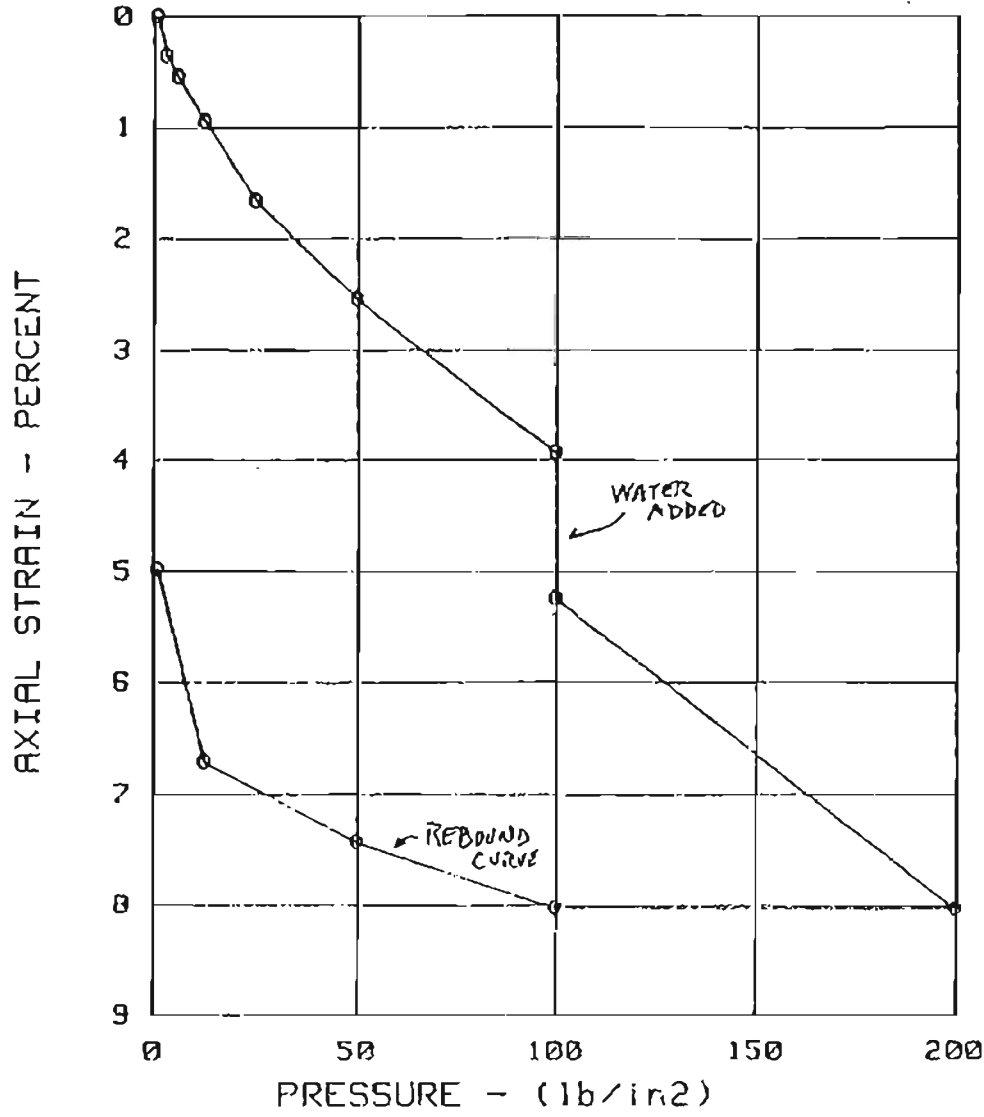

SAMPLE NO. G1Y-16	SPEC No. 51	SPEC SIZE 4.25X1.25	UNDISTURBED
CLASS SYMBOL : CL	HOLE No. : DH-614	DEPTH : 109-111	ft.

FIGURE 20

MECHANICAL PROPERTIES OF ROCKFILL

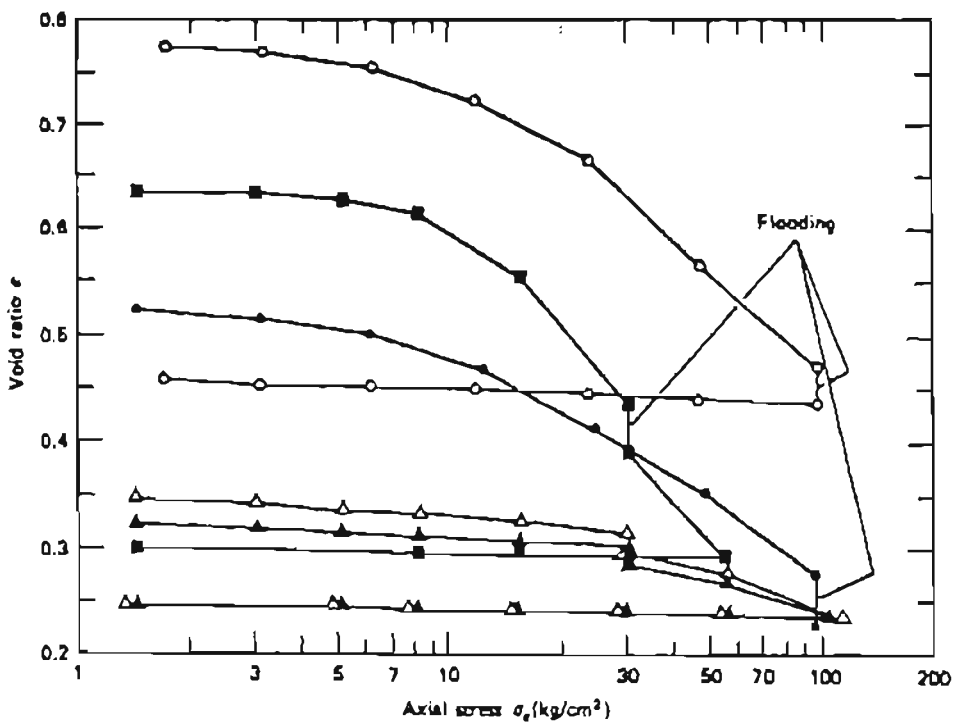

Material	Sample symbol
Sand and gravel from Pinzandarán	1 x
Infiernillo Dam Quarry No. 1	2 o
Infiernillo Dam Quarry No. 5	3 •
Malpaso Dam	4 +
San Francisco grad. 1	5 Δ
San Francisco grad. 2	6 ▲
Mica Dam grad. X	7 □
Mica Dam grad. Y	8 ■
El Granero Dam grad. A	9 ◇
El Granero Dam grad. B	10 ⊠

Note: For characteristics of samples tested see Table 20

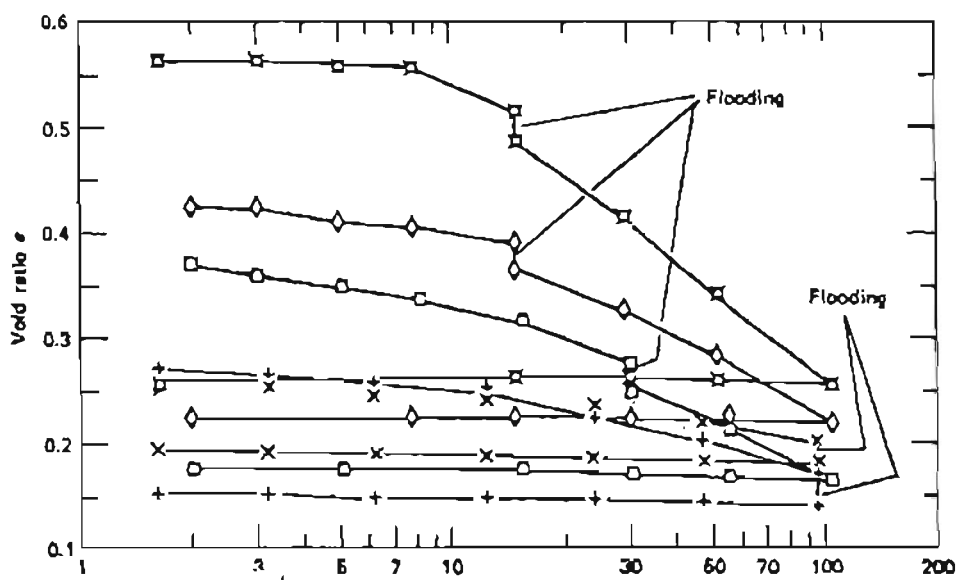

Void ratio-pressure curves for materials tested in apparatus O-114-100.

(From Embankment Dam Engineering) [10]

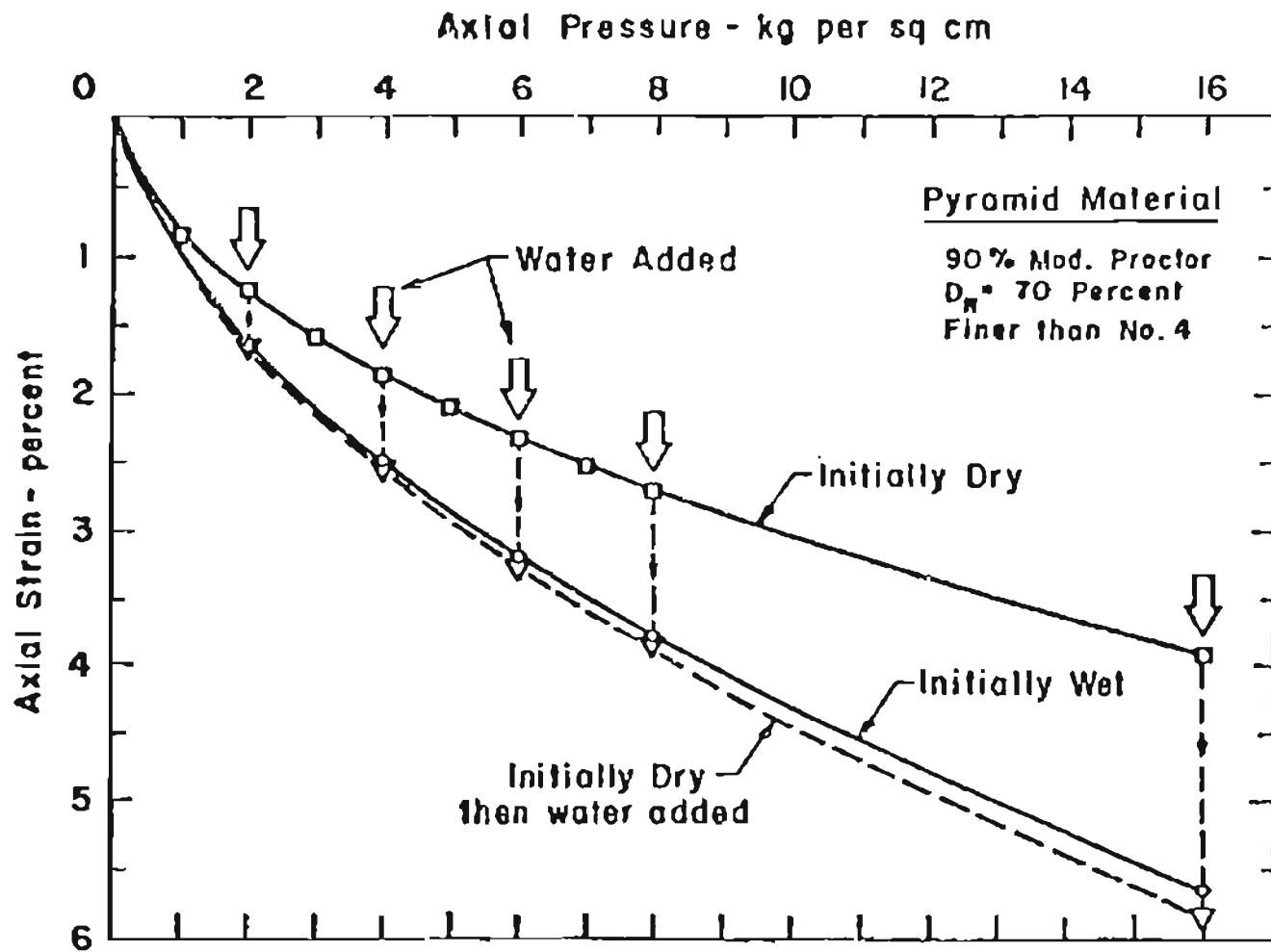

COMPRESSION AND COLLAPSE OF PYRAMID MATERIAL,  $C_u = 14$ ,  
5% PASSING NO. 200 SIEVE

( From Nobari and Duncan ) [4]

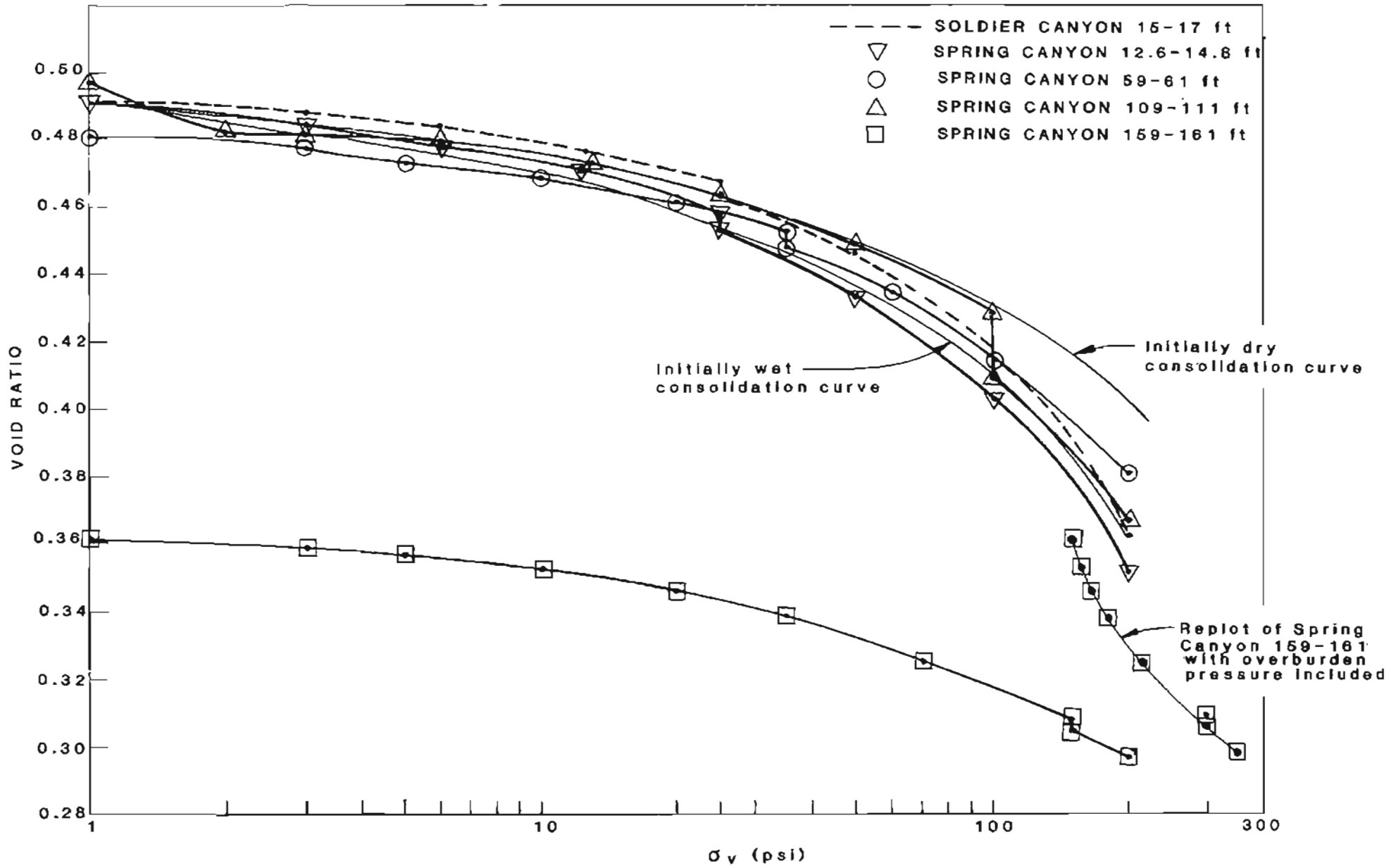

ONE-DIMENSIONAL CONSOLIDATION TEST DATA

FIGURE 23

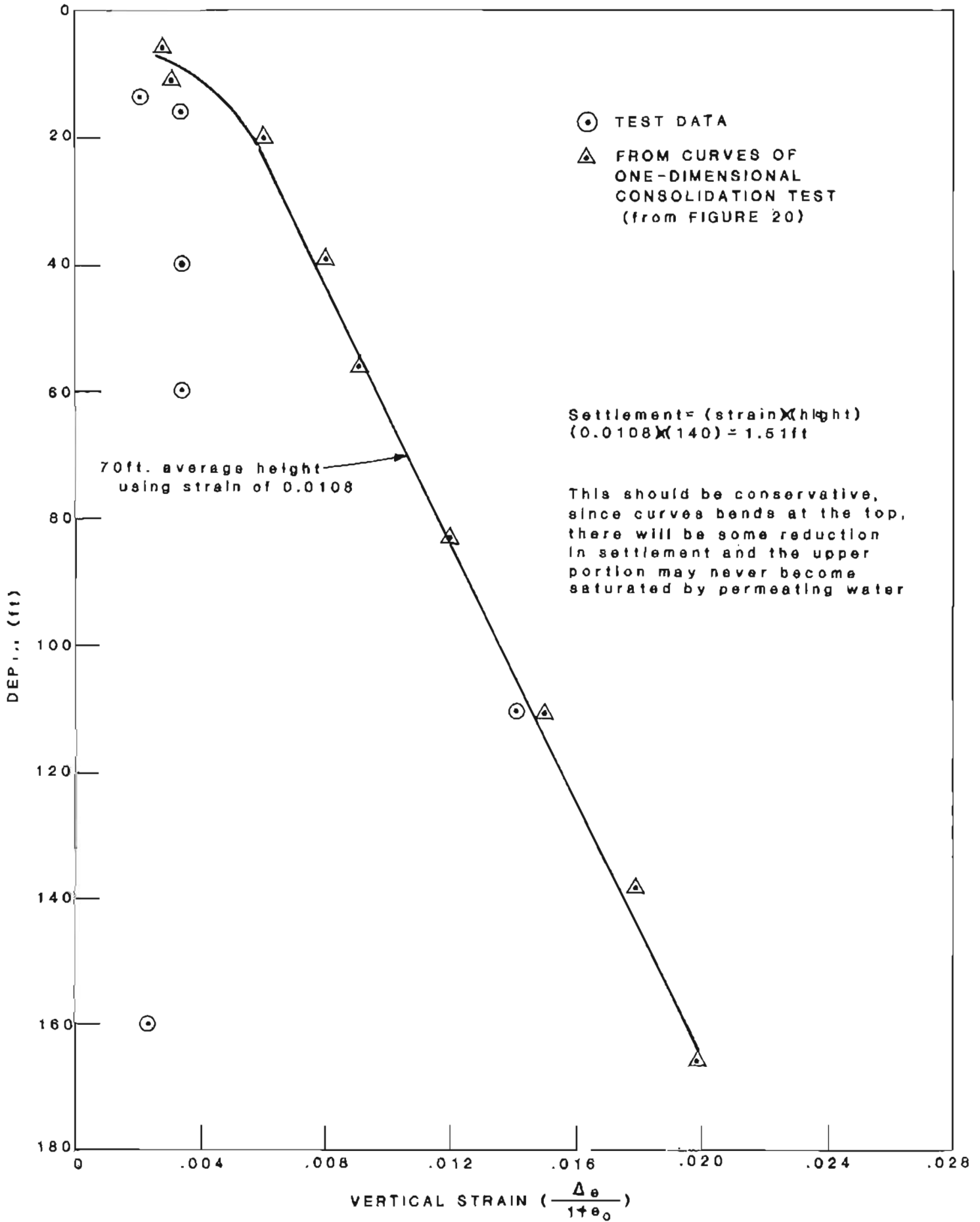

STRAIN vs DEPTH

FIGURE 24

## **Appendix B**

*Part 3* Ridges Basin Dam – Embankment Settlement and Construction  
Pore Pressures

(Adapted from Technical Memorandum No. RB-8311-39 dated July 2008)



Ridges Basin Dam (near Durango, Colorado). View showing foundation excavation during construction.



# INTRODUCTION

The proposed Lake Nighthorse, the reservoir impounded by Ridges Basin Dam, will be the primary storage feature of the Animas-LaPlata Project. The damsite is located approximately 3.5 miles southwest of Durango, Colorado in La Plata County. Ridges Basin Dam will be an offstream storage facility impounding water pumped from the Animas River.

The dam will be a central core embankment with a crest length of approximately 1,600 feet at elevation 6893. Prior to embankment placement, foundation excavation will remove all alluvial materials beneath the embankment footprint to expose rock [1]<sup>1</sup>. The embankment will be constructed to a structural height of approximately 275 feet as shown in Figure 1.

Some changes occurred in the final design throughout the nearly four years of construction. Where the changes were of at least moderate significance, discussion of the change is included here with specific notations as a “Construction change” or “Construction note”.

Construction note: During construction, the lowest elevation of the embankment’s foundation occurred at Station 19+65, Offset 412.48 feet downstream from centerline. The elevation at this point was 6620.3 feet making the structural height of the embankment 273 feet. The final crest length at the end of construction was 1,633 feet.

## PREVIOUS DESIGN OF RIDGES BASIN DAM

A previous design for Ridges Basin Dam had a structural height of approximately 345 feet as described by Dinneen and Goldsmith (1996) [2]. The previous design (termed here as the ‘1995 design’) allowed for excavation and removal of the unsaturated, collapsible portion of the alluvium that lies above the water table. Below this, the saturated alluvium was removed beneath the central core area and downstream shell, but not under the upstream shell. This removal was to be performed to eliminate foundation settlement that could lead to unacceptable settlements of the overlying embankment. The previous design’s use of an upstream shell composed of compacted fine grained material allowed underlying alluvium to be left in place. However, this required installation of wick drains as the method of foundation treatment for the alluvium. These wick drains were intended to increase the rate of porewater pressure dissipation as the overlying earthfill was being placed and would allow for some of the eventual settlement to occur as the embankment was being raised.

The previous design utilized staged construction to manage construction induced porewater pressures. Stage I construction included: (i) excavation to the dam foundation and foundation treatment; (ii) installation of wick drains and upper cap to serve as a sand drainage blanket; (iii) placement of downstream sand and gravel foundation materials; (iv) installation of a cement-bentonite cutoff wall; and (v) placement of surcharge shell material above the wick drains. Stage II construction included placement of the remaining zones within the dam.

---

<sup>1</sup> Superscript numbers in brackets refer to entries in the list of references at the end of this report.

## **GENERAL COMMENTARY**

The reformulated project that results in a lower dam affords certain improvements to be made in the new design from the 1995 design. Rather than simply adopt the previous design to the revised dam height, the opportunity was taken to adjust the new design to the site conditions as was beneficial to performance and economic issues. Much of the previous design concepts, testing, and analyses that had been performed were again used in the re-design described herein as was practical. Instances of this are included in the following discussions.

Prior to discussion of specific aspects of the proposed final design, it is necessary to clarify issues of a general nature relating to the subject dam as well as applicable information relevant to the state-of-the-art in dam engineering. In addition, several comparisons are made between the proposed embankment design and a previous design described by Dinneen and Goldsmith (1996) [2].

The axis of the new dam was chosen to be the same as the 1995 design. Extensive foundation investigations had already been completed supporting this alignment. Lacking a good reason to move the alignment, it was kept the same.

## **PREVIOUS ANALYSIS**

A study to determine consolidation and pore pressure characteristics of the alluvial foundation materials was performed in 1992 [3]. The previous embankment configuration included an upstream and central clay core with a downstream filter and shell. The design for foundation excavation included removal of the upper 30 feet of alluvium beneath the embankment, and leaving the lower 45 to 65 feet of compressible clay in place as shown in Figure 2. The design was later modified to remove foundation alluvium beneath the downstream shell, but settlement and consolidation studies were apparently not updated for the newer design.

Excess pore pressures at a location 200 feet upstream of the crest were estimated to be 361 feet of head in the core at the end of construction. The maximum post-construction embankment settlement at the crest was estimated to be 2.2 feet, or 0.7 percent of the then-maximum embankment height of 314 feet. Foundation consolidation measured at the crest was estimated to be 6.7 feet. The total estimated settlement at the crest due to embankment compression and foundation consolidation was therefore 8.9 feet.

Since the 1992 design, the project was reformulated to accommodate an embankment to impound 120,000 acre-feet of water.

## **PURPOSE**

The purpose of this Technical Memorandum is to document the analyses and evaluations for estimated embankment settlement and for construction pore pressures for the new embankment cross section. A recommendation for camber requirements will also be presented.

## CRITERIA

The guidelines in Embankment Dams Design Standards No. 13, *Static Deformation Analysis* [4] were used for evaluating embankment settlement. Construction pore pressures were estimated using the Hilf Method [5].

## EMBANKMENT SETTLEMENT

Instrumentation data presented in the literature [6, 7, 8] for compacted embankments constructed on stiff foundations using modern equipment and in accordance with Reclamation standards indicates post construction settlements generally range from 0.2 percent and 0.4 percent, and seldom exceed 0.5 percent of the embankment height. Based on this performance history, a “rule of thumb” for conservative camber design using 1 percent of the embankment height has become common practice [9].

Typically, the 1% “rule of thumb” is not sufficiently analytical for calculating deformations of moderate to high risk dams or dams exceeding 200 feet in height, except for preliminary camber design. However, the conditions at Ridges Basin Dam are favorable for relatively small static deformations. These conditions include:

- Complete removal of alluvial materials in the foundation.
- Embankment materials will be strong when compacted.
- Strong, pervious upstream and downstream shells surround the central clay core.

Based on the conditions listed above, a simplified, “rule of thumb” approach to camber design is therefore judged to be appropriate. Precedence from a study of completed dams will be used instead to predict the final settlement amount

## CASE HISTORIES

A review of the post-construction settlement performance of dams similar to Ridges Basin Dam was performed to help determine camber design. Table 1 summarizes the comparison between these dams and Ridges Basin Dam. Current maximum observed settlements at Ridgway and McPhee Dams are approximately 0.3 percent of the structural height, and 0.4 percent of the structural height at New Waddell Dam. The settlement curves shown in the Appendix indicate minor settlement is still occurring at McPhee Dam and New Waddell Dam, while settlement at Ridgway Dam has slowed to a very small rate.

## SELECTION OF CAMBER REQUIREMENT

The 1% “rule of thumb” for camber design may be overly conservative because it is largely based on older dams with less stringent construction control than would be used today. Additionally, embankments compacted at moisture contents below optimum can significantly reduce post-construction settlement as demonstrated in a 3-D finite element analysis for New Waddell Dam [10]. It is anticipated that the specifications for Ridges Basin Dam will require placement of Zone 1 core materials at a water content similar to the case studies listed above.

Construction of the embankment at Ridges Basin Dam is anticipated to occur over 21 months. Since the rate of settlement is greatest following placement, a significant portion of embankment settlement is expected prior to completion of the embankment. Camber design therefore considers only the post-construction settlement anticipated.

Construction note: Due to funding and contracting issues, the construction of the dam was broken up into multiple work products (i.e. contracts) that separated out portions of the work. Placement of the first embankment materials on the foundation occurred mid-summer 2005 and the embankment was topped on November 16, 2007, a period of about 28 months.

The 1992 design used 0.7% of the maximum embankment height for the estimated embankment compression. Based on a review of relevant case histories and a consideration of the site-specific conditions at Ridges Basin, this value is believed to be conservative but reasonable. Therefore 0.7% of the embankment height was kept as the estimated post-construction settlement for the new dam. For a maximum height below the crest of 273 feet, the maximum camber will be 2 feet (rounded up from 1.9 feet).

## **CONSTRUCTION PORE PRESSURES**

The chosen cross section of the embankment is fairly immune to the effects of high, construction generated pore pressures in the core. The very pervious shell, filter, and drain materials will all eliminate excess pore pressures in the embankment's shell. As the shell provides the majority of the embankment's stability, the strength of the shell material will not be diminished by pore pressure buildup and thus the stability will not be significantly affected.

Nonetheless, construction induced pore pressure buildup in the core was estimated to enable a more realistic stability calculation to be made. To estimate the pore pressure generated by consolidation of compacted impervious earthfill under self-weight, the Hilf procedure [5] was used. The method assumes that no dissipation of these pressures occurs during construction. This procedure is intended to estimate porewater pressures acting along the centerline of a rolled earth fill. The calculations indicate the porewater pressure heads would vary from approximately zero at the embankment crest to approximately 45 feet of water head at the contact between the embankment and bedrock, as shown on Figure 3.

Excess porewater pressures are not anticipated to be developed within the Lewis Shale or Pictured Cliffs Sandstone foundation materials during construction. The primary and secondary permeability of the Pictured Cliffs Sandstone is great enough to eliminate any significant pore pressure buildup. Fractures and bedding planes within the Lewis Shale are closely spaced and more pervious than the massive rock thus any porewater pressures generated are expected to dissipate readily throughout construction.

The estimated porewater pressure heads were input to the stability model used for the end-of-construction case. This was accomplished by specifying a grid of heads within the Zone 1 material as shown on Figure 3. The heads estimated along the dam centerline were conservatively specified at the upstream and downstream limits of Zone 1. No phreatic surface was specified. A zero head boundary condition was specified at discrete points within the

upstream transition zone and the downstream filter material as shown on Figure 3 because these zones are significantly more pervious than the Zone 1 and act as drainage boundaries. Due to the pervious nature of other embankment zones, no excess porewater pressures are anticipated within these materials during construction.

Additional details of pore pressure during construction and their affects on stability can be found in Technical Memorandum RB-8313-35 [11]. The end-of-construction stability was shown to be adequate.

## **CONCLUSIONS**

The conditions at Ridges Basin Dam are favorable for small static deformations because alluvial materials will be removed from the foundation, and embankment materials will be well compacted.

Foundation consolidation will be negligible with the removal of the alluvium materials to rock beneath the footprint of the dam. The calculation of settlement will therefore only consider the anticipated embankment compression.

The maximum camber, corresponding to the maximum section, was selected to be 2 feet. Proportionally smaller amounts of camber will be designed for areas with lesser embankment heights. Camber will be zero feet at both abutment contacts.

Construction pore pressures were estimated and incorporated into the stability analyses.

Table 1: Measured settlements for recent Reclamation Embankment Dams

Dam	Completed Year	Foundation	Structural Height (ft)	Settlement (%)
McPhee	1984	central core; chimney filter; upstream and downstream coarse shells	282	Crest 0.26 <sup>1</sup>
Ridgway	1987	central core; downstream filter; upstream and downstream coarse shells	330	0.28 <sup>2</sup>
New Waddell	1992	high PI central core; upstream and downstream filters; upstream and downstream coarse shells	90 ft alluvium	0.36 <sup>3,4</sup>

<sup>1</sup> Based on the maximum settlement through September 1999.

<sup>2</sup> Based on the maximum settlement through July 2001.

<sup>3</sup> Based on the maximum settlement through December 1999.

<sup>4</sup> Includes both embankment settlement and foundation consolidation

---

## References

- [1] “Embankment Zoning Design,” *Technical Memorandum No. RB-8313-36*, Ridges Basin Dam, Animas-La Plata Project, Colorado - New Mexico, Bureau of Reclamation, Denver, CO, July 2008.
- [2] “Embankment Zoning Design,” *Technical Memorandum No. RB-3620-8*, Ridges Basin Dam, Animas-La Plata Project, Colorado - New Mexico, Bureau of Reclamation, Denver, CO, 1996.
- [3] “Design Summary for Ridges Basin Dam, Volume I,” *Technical Memorandum No. RB-3620-2, Foundation and Embankment Settlement, Rates of Consolidation, and Construction Pore Pressures*, Bureau of Reclamation, Denver, CO, September 1, 1992.
- [4] “Embankment Dams Design Standards No. 13, Chapter 9,” *Static Deformation Analysis*, Bureau of Reclamation, Denver, CO, August 5, 1992.
- [5] Hilf, J. W. *A Method for Predicting Pore Pressures*, Bureau of Reclamation, Denver, CO, May 1961.
- [6] Earth and Earth Rock Dams, By Sherard, James L., Woodward, Richard J., Gizienski, Stanely F., and Clevenger, William A., John Wiley and Sons, New York, NY, 1963.
- [7] Embankment Dam Engineering, Deformation of Earth and Rockfill Dams, By Wilson, Stanely D., John Wiley and Sons, New York, NY, 1973.
- [8] “Technical Memorandum 648,” *Compression Characteristics of Rolled Fill Materials in Earth Dams*, Prepared by Gould, James P., Bureau of Reclamation, Denver, CO, 1954.
- [9] Design of Small Dams, 3<sup>rd</sup> Edition, Bureau of Reclamation, Denver, CO, 1987.
- [10] “Technical Memorandum for New Waddell Dam,” *Deformation Analysis*, Woodward-Clyde Consultants, 1989.
- [11] “Static Stability Analyses for Ridges Basin Dam,” *Technical Memorandum No. RB-8313-35*, Bureau of Reclamation, Denver, CO, July 2008.



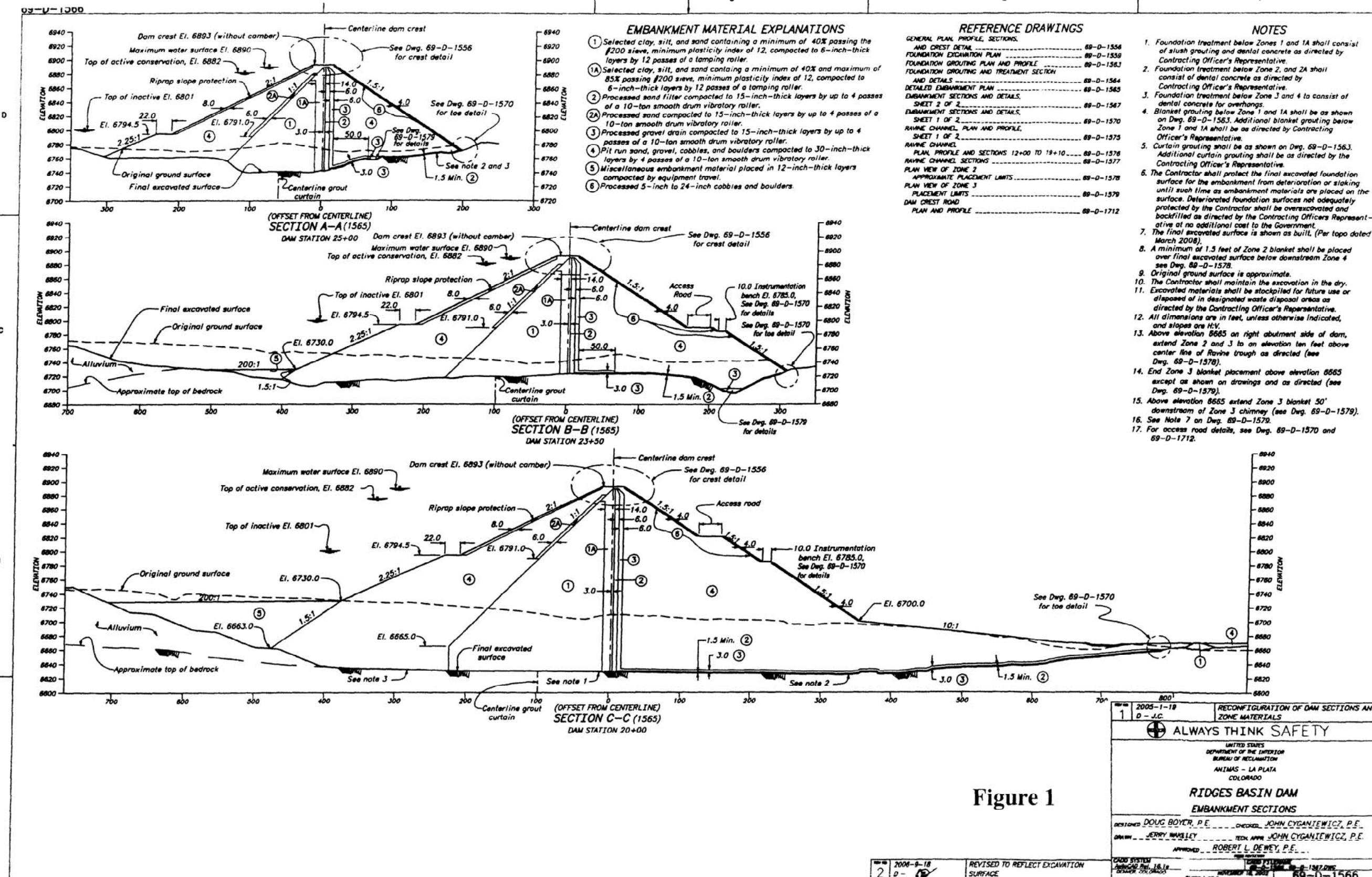

**EMBANKMENT MATERIAL EXPLANATIONS**

- ① Selected clay, silt, and sand containing a minimum of 40% passing the #200 sieve, minimum plasticity index of 12, compacted to 6-inch-thick layers by 12 passes of a tamping roller.
- ①A Selected clay, silt, and sand containing a minimum of 40% and maximum of 85% passing #200 sieve, minimum plasticity index of 12, compacted to 6-inch-thick layers by 12 passes of a tamping roller.
- ② Processed sand filter compacted to 15-inch-thick layers by up to 4 passes of a 10-ton smooth drum vibratory roller.
- ②A Processed sand compacted to 15-inch-thick layers by up to 4 passes of a 10-ton smooth drum vibratory roller.
- ③ Processed gravel drain compacted to 15-inch-thick layers by up to 4 passes of a 10-ton smooth drum vibratory roller.
- ④ Pit run sand, gravel, cobbles, and boulders compacted to 30-inch-thick layers by 4 passes of a 10-ton smooth drum vibratory roller.
- ⑤ Miscellaneous embankment material placed in 12-inch-thick layers compacted by equipment travel.
- ⑥ Processed 5-inch to 24-inch cobbles and boulders.

**REFERENCE DRAWINGS**

GENERAL PLAN, PROFILE, SECTIONS, AND CREST DETAIL	69-D-1556
FOUNDATION EXCAVATION PLAN AND PROFILE	69-D-1558
FOUNDATION GROUTING AND TREATMENT SECTION AND DETAILS	69-D-1564
EMBANKMENT SECTIONS AND DETAILS, SHEET 2 OF 2	69-D-1567
EMBANKMENT SECTIONS AND DETAILS, SHEET 1 OF 2	69-D-1570
RAVINE CHANNEL, PLAN AND PROFILE, SHEET 1 OF 2	69-D-1575
RAVINE CHANNEL, PLAN, PROFILE AND SECTIONS 12+00 TO 19+10	69-D-1576
RAVINE CHANNEL SECTIONS	69-D-1577
PLAN VIEW OF ZONE 2 APPROXIMATE PLACEMENT LIMITS	69-D-1578
PLAN VIEW OF ZONE 3 PLACEMENT LIMITS	69-D-1579
DAM CREST ROAD PLAN AND PROFILE	69-D-1712

**NOTES**

1. Foundation treatment below Zones 1 and 1A shall consist of slush grouting and dental concrete as directed by Contracting Officer's Representative.
2. Foundation treatment below Zone 2, and 2A shall consist of dental concrete as directed by Contracting Officer's Representative.
3. Foundation treatment below Zone 3 and 4 to consist of dental concrete for overhangs.
4. Blanket grouting below Zone 1 and 1A shall be as shown on Dwg. 69-D-1563. Additional blanket grouting below Zone 1 and 1A shall be as directed by Contracting Officer's Representative.
5. Curtain grouting shall be as shown on Dwg. 69-D-1563. Additional curtain grouting shall be as directed by the Contracting Officer's Representative.
6. The Contractor shall protect the final excavated foundation surface for the embankment from deterioration or staking until such time as embankment materials are placed on the surface. Deteriorated foundation surfaces not adequately protected by the Contractor shall be overexcavated and backfilled as directed by the Contracting Officer's Representative at no additional cost to the Government.
7. The final excavated surface is shown as built, (Per topo dated March 2008).
8. A minimum of 1.5 feet of Zone 2 blanket shall be placed over final excavated surface below downstream Zone 4 see Dwg. 69-D-1578.
9. Original ground surface is approximate.
10. The Contractor shall maintain the excavation in the dry.
11. Excavated materials shall be stockpiled for future use or disposed of in designated waste disposal areas as directed by the Contracting Officer's Representative.
12. All dimensions are in feet, unless otherwise indicated, and slopes are H:V.
13. Above elevation 6665 on right abutment side of dam, extend Zone 2 and 3 to an elevation ten feet above center line of Ravine trough as directed (see Dwg. 69-D-1578).
14. End Zone 3 blanket placement above elevation 6665 except as shown on drawings and as directed (see Dwg. 69-D-1579).
15. Above elevation 6665 extend Zone 3 blanket 50' downstream of Zone 3 chimney (see Dwg. 69-D-1579).
16. See Note 7 on Dwg. 69-D-1579.
17. For access road details, see Dwg. 69-D-1570 and 69-D-1712.

**Figure 1**

2005-1-18 D-JC	RECONFIGURATION OF DAM SECTIONS AND ZONE MATERIALS
<b>ALWAYS THINK SAFETY</b>	
UNITED STATES DEPARTMENT OF THE INTERIOR BUREAU OF RECLAMATION ANIMAS - LA PLATA COLORADO	
<b>RIDGES BASIN DAM EMBANKMENT SECTIONS</b>	
DESIGNED DOUG BOYER, P.E.	CHECKED JOHN CYGANIEWICZ, P.E.
DRAWN JERRY HAVELLEY	TECH. APPR. JOHN CYGANIEWICZ, P.E.
APPROVED ROBERT L. DEWEY, P.E.	
2006-9-18 D-JC	REVISED TO REFLECT EXCAVATION SURFACE
2005-1-18 D-JC	69-D-1566



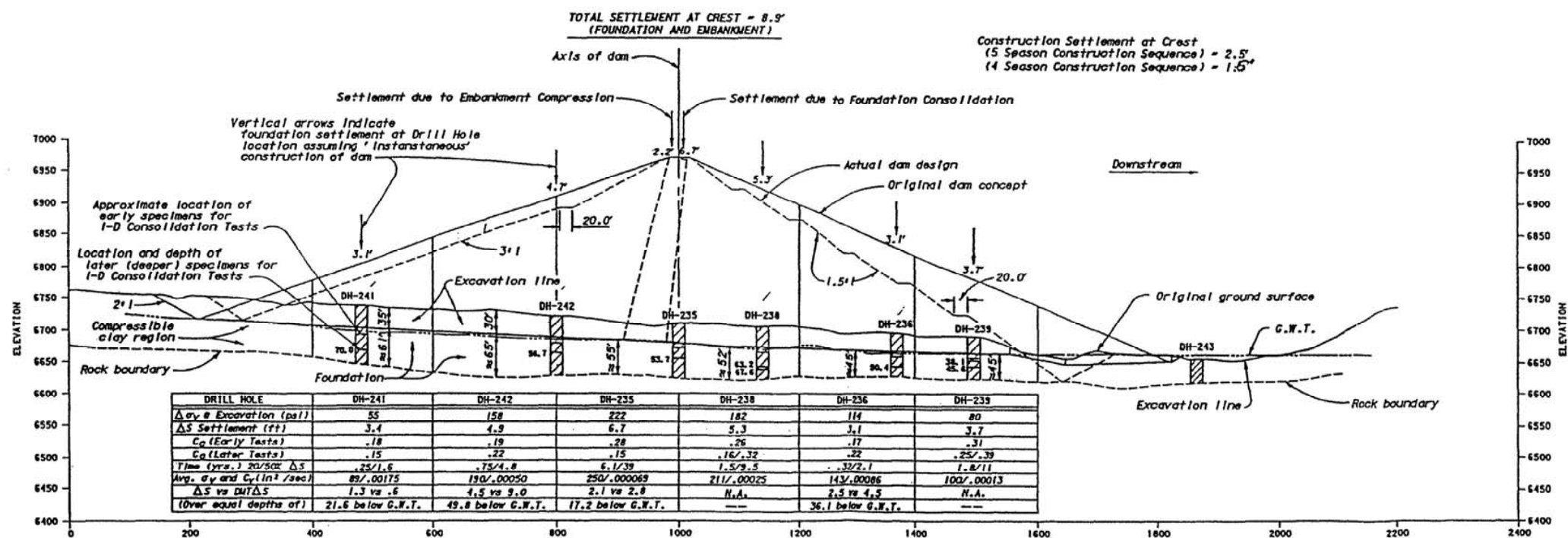
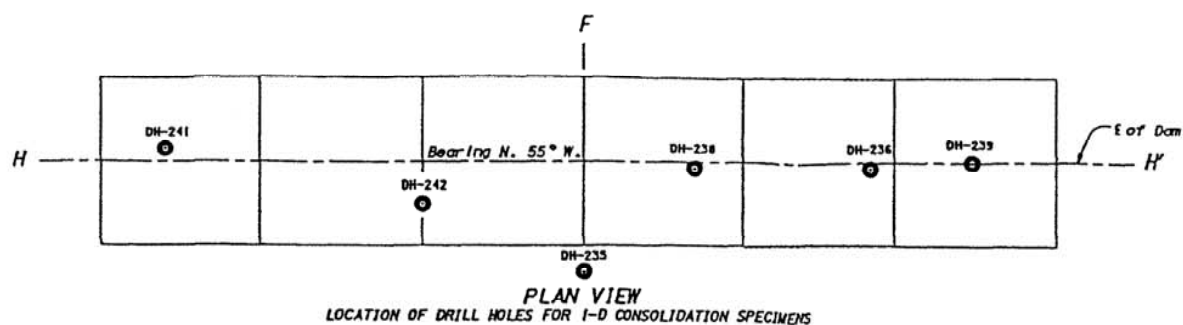

**EXPLANATION OF PROPERTIES**

Δ<sub>av</sub> = Increase in effective pressure from dam  
 C<sub>c</sub> = Compression Index (Included for comparison, not used to calculate settlement)  
 C<sub>v</sub> = Consolidation coefficient, based on average dam pressure over the drill hole, and are taken from Early I-D Consolidation Tests  
 ΔS = Calculated total foundation settlement, in feet, using change in void ratio  
 DUT ΔS = In situ foundation settlement, Dilatometer Test, comparison based on equivalent depths  
 N.A. = Dilatometer did not sample this drill hole

**NOTES**

All settlements are based on the Original Dam Concept. All depths noted for specimens used in consolidation tests are referenced to the original ground level. Unless otherwise noted, all settlements refer to foundation consolidation and are based on the Original Dam Concept. The dilatometer tests were conducted adjacent to the drill holes shown. The dilatometer test data may be best utilized as an indication of the vertical extent of the compressible clay layer since the settlement calculated from the consolidation test specimen assumes a continuous isotropic clay layer over depth while the DUT ΔS is based on data gathered every 0.2 meters. Early consolidation tests—one test per drill hole, each specimen located approximately 5 to 10 feet below the water table (G.W.T.). The approximate depth is noted at the drill holes with a dash mark. Tests were completed in 1990. Later consolidation tests—additional test(s) in each drill hole and located from approximately 15 to 35 feet below G.W.T.. Each later specimen location has a depth noted adjacent to it. These tests were completed in 1991.

**MAXIMUM SECTION OF PRELIMINARY DAM CONCEPT**

Summary of Settlements, Rates of Consolidation, and Consolidation Properties  
 1992 Analysis

**Figure 2**

ALWAYS THINK SAFETY

UNITED STATES  
 DEPARTMENT OF THE INTERIOR  
 BUREAU OF RECLAMATION  
 ANIMAS - LA PLATA - COLORADO

**RIDGES BASIN DAM**

**SETTLEMENT AND CONSOLIDATION RATES**

DESIGNED: RICE, BENTON      TECHNICAL APPROVAL: \_\_\_\_\_  
 DRAWN: B.L. SANCHEZ      SUBMITTED: \_\_\_\_\_  
 CHECKED: \_\_\_\_\_      APPROVED: \_\_\_\_\_

DOVER, COLORADO      JAN. 14, 1991      102-GEO-1

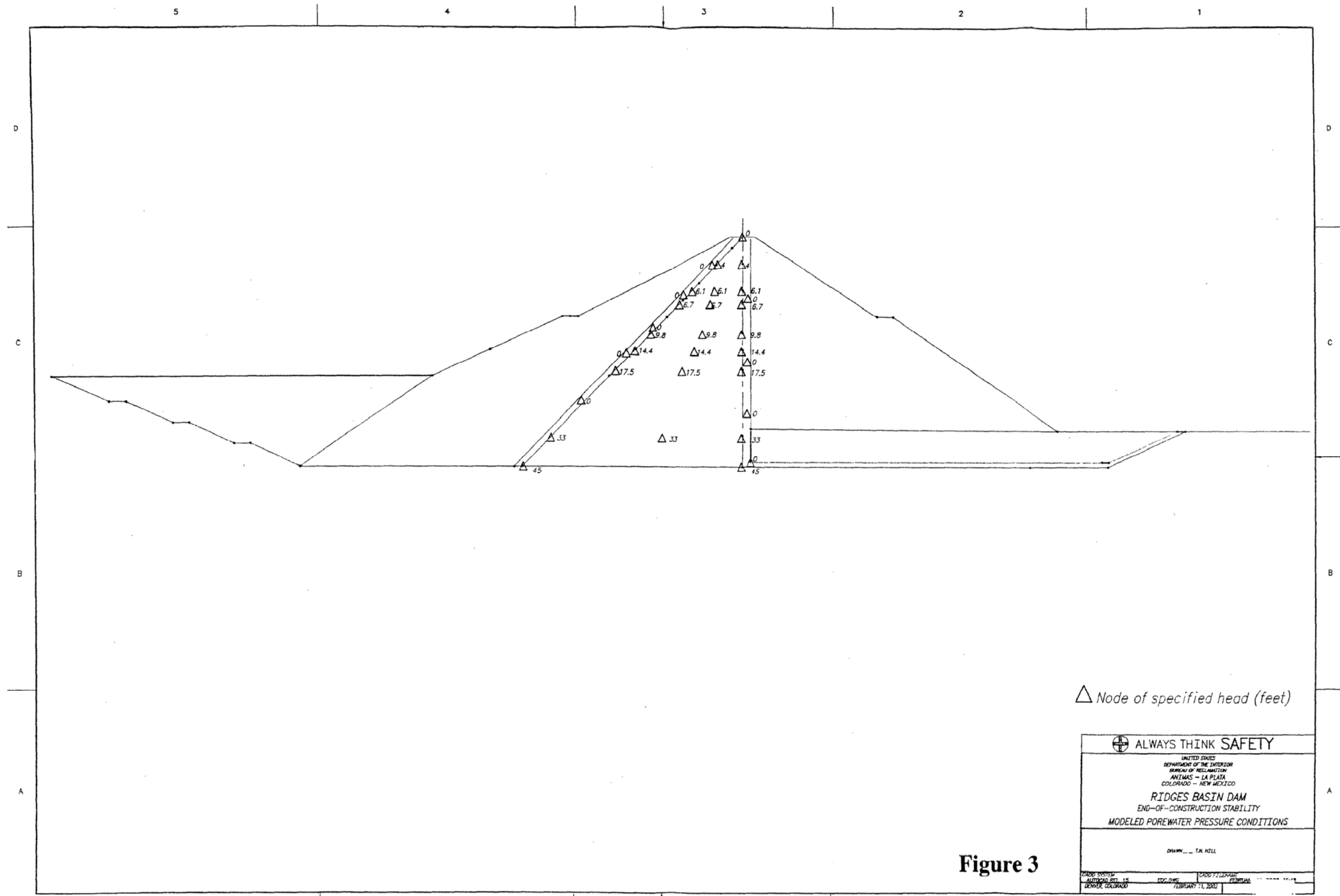



Figure 3

△ Node of specified head (feet)

 ALWAYS THINK SAFETY	
<small>UNITED STATES DEPARTMENT OF THE INTERIOR BUREAU OF RECLAMATION ANIMAS - LA PLATA COLORADO - NEW MEXICO</small>	
<b>RIDGES BASIN DAM</b> <small>END-OF-CONSTRUCTION STABILITY          MODELED POREWATER PRESSURE CONDITIONS</small>	
<small>DRAWN BY: TAJ HILL</small>	
<small>GRAPH SYSTEM AUTOCAD R15 DENVER, COLORADO</small>	<small>SCALE: 1" = 100' DATE: FEBRUARY 11, 2002</small>

# Appendix

# McPHEE DAM CREST SETTLEMENT

——— 019U\_7+  
 - - - 019U\_10+  
 - · - 019U\_12+  
 - · - · 019U\_15+

——— 30D\_7+  
 - - - 30D\_10+  
 - · - 30D\_12+  
 - · - · 30D\_15+

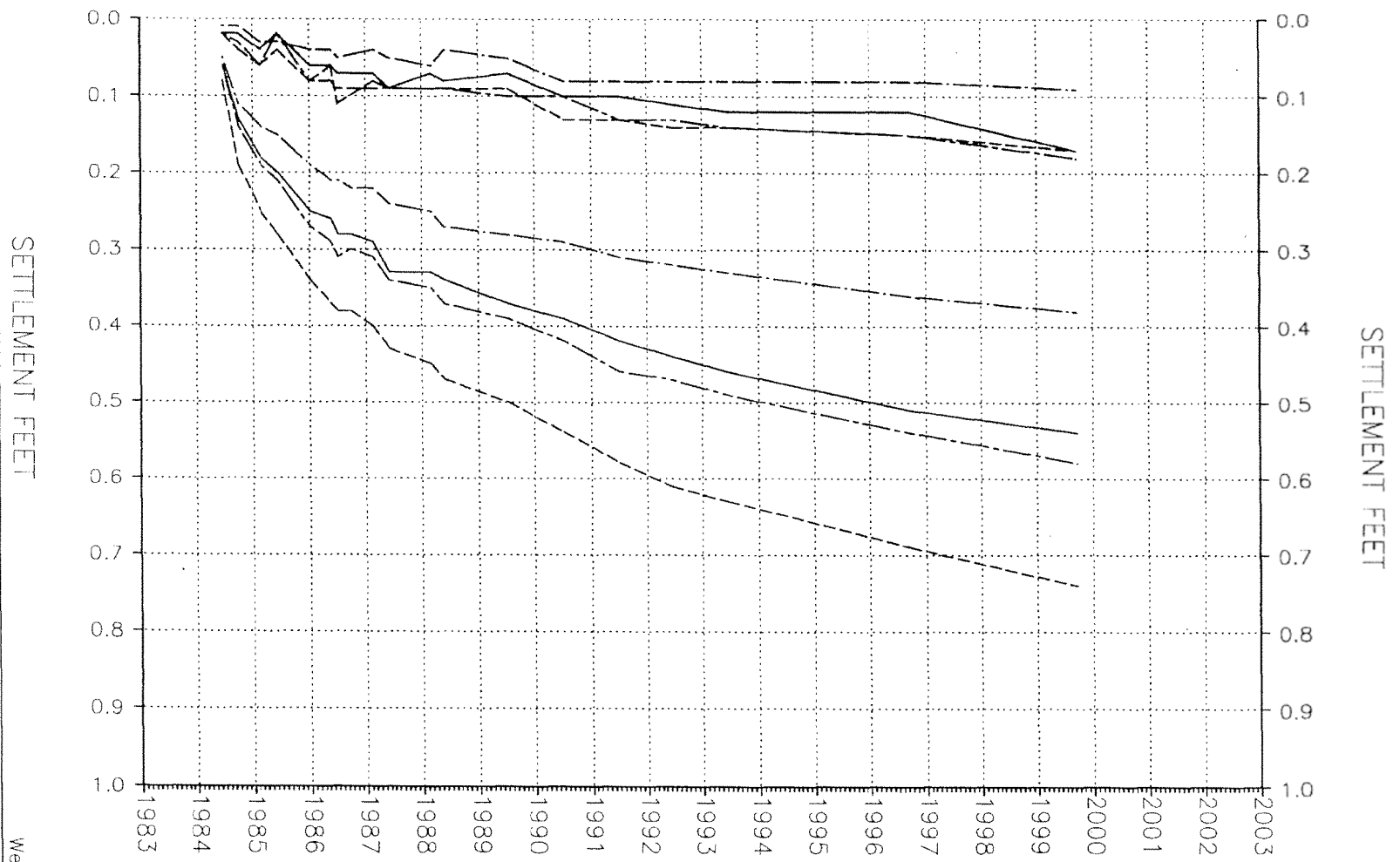

Welch

# NEW WADDELL DAM CREST SETTLEMENT TIME PLOT

- |  |  |  |
|--|--|--|
| <ul style="list-style-type: none"> <li>— OldReserv</li> <li>- - - ARes</li> <li>- · - Tailwater</li> </ul> | <ul style="list-style-type: none"> <li>— P135 U/S Crest Sta. 35</li> <li>- - - P137 U/S Crest Sta. 37</li> <li>- · - P139 U/S Crest Sta. 39</li> <li>- · - P141 U/s Crest Sta. 41</li> </ul> | <ul style="list-style-type: none"> <li>— P236 D/S Crest Sta. 36</li> <li>- - - P238 D/S Crest Sta. 38</li> <li>- · - P239+75 D/S Crest Sta. 39+75</li> <li>- · - P242 D/S Crest Sta. 42</li> </ul> |
|--|--|--|

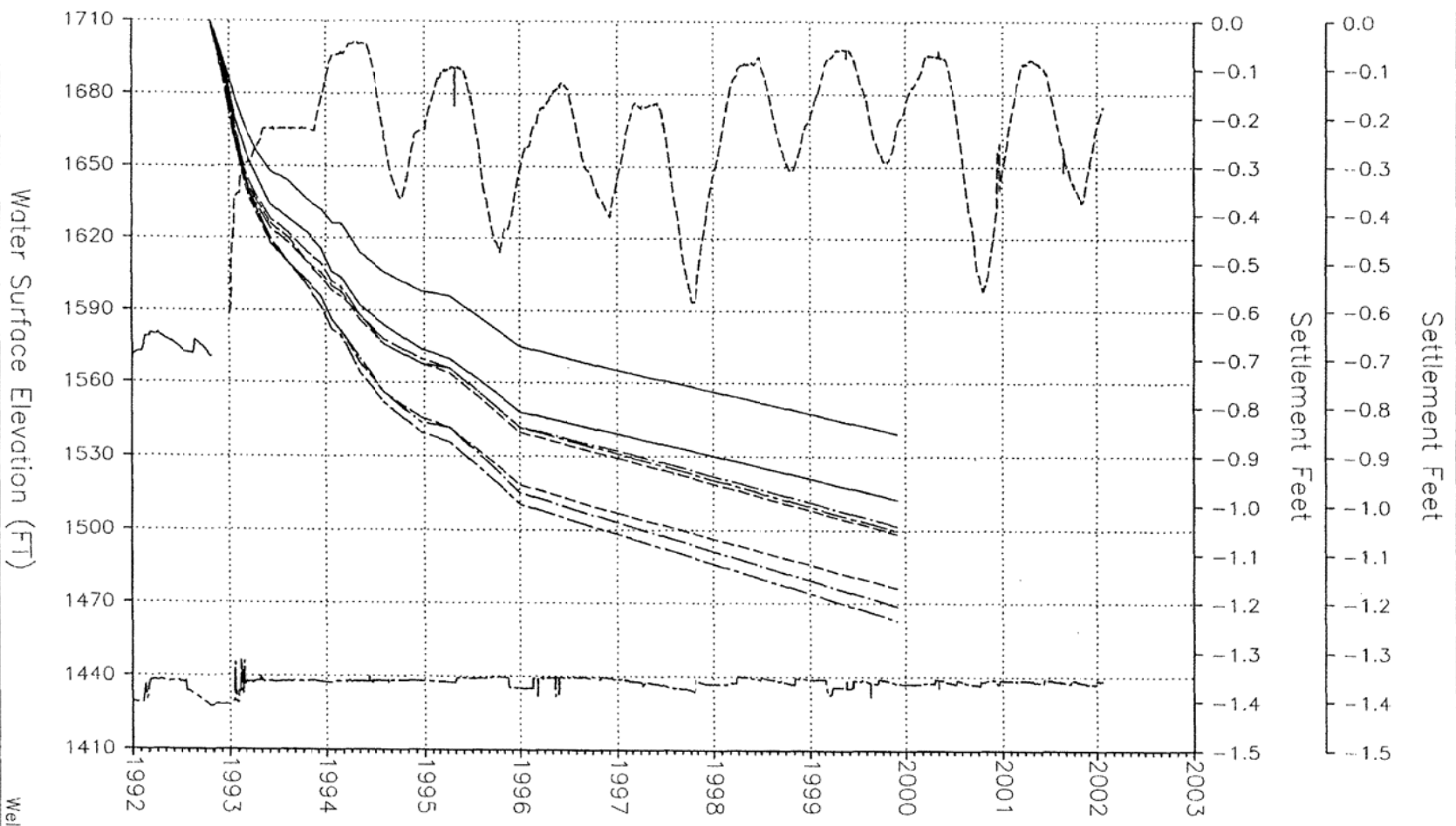

Welch

Ridgway Dam – Embankment Measurement Points  
 Dam Crest – Settlement (Sta. 15+00 – 20+00)

- |           |         |           |         |
|-----------|---------|-----------|---------|
| —         | 17U_15+ | —         | 17D_16+ |
| - - -     | 17U_17+ | - - -     | 17D_18+ |
| - . - . - | 17U_19+ | - . - . - | 17D_20+ |
| - . - . - | 17U_21  | - . - . - | 17D_22  |

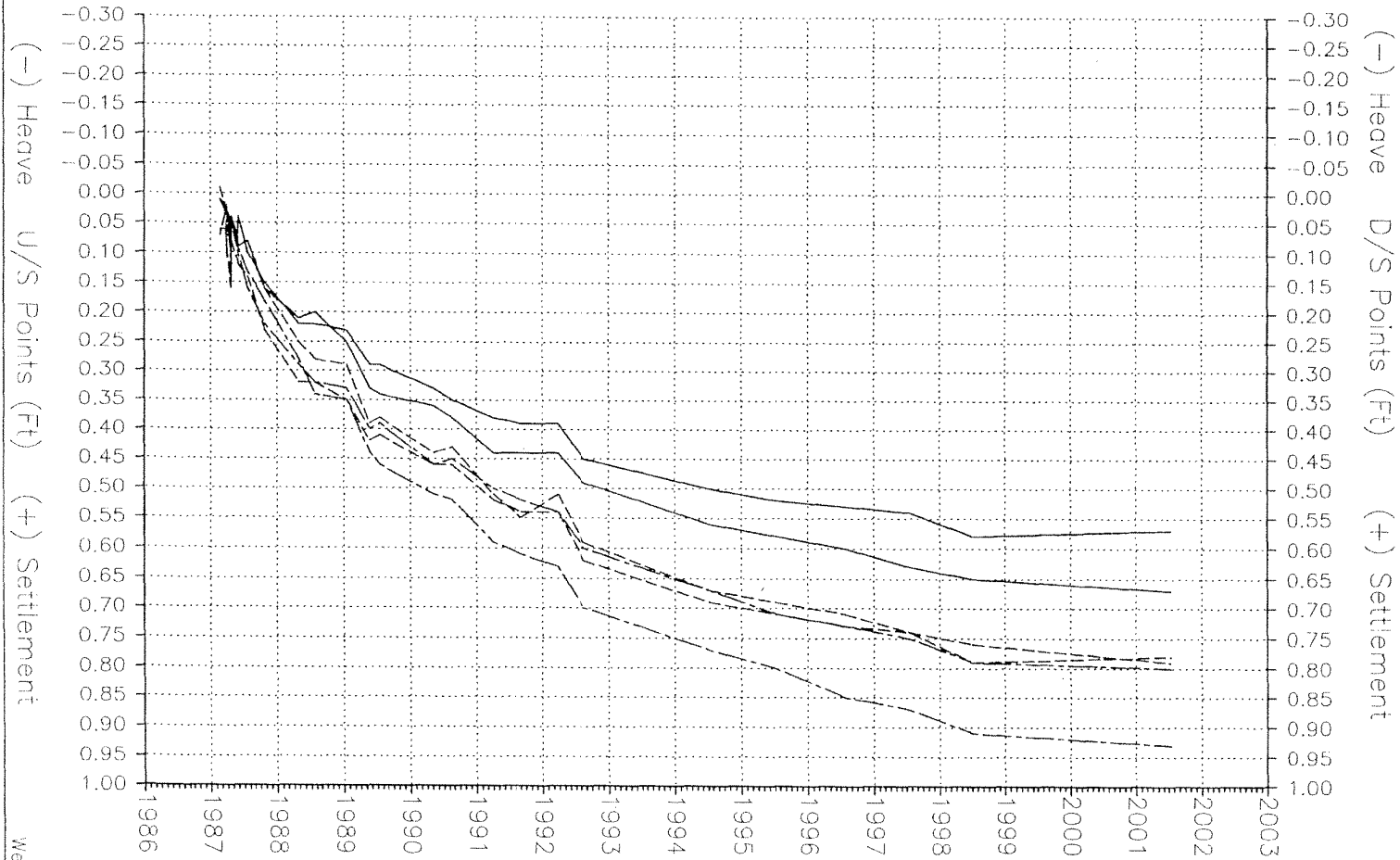

Welch